

ORDINANCE NO. 3833

AN ORDINANCE OF THE CITY OF KIRKLAND RELATING TO ZONING, PLANNING, AND LAND USE AND AMENDING PORTIONS OF ORDINANCE 3719 AS AMENDED, THE KIRKLAND ZONING ORDINANCE (FILE NO. IVA-01-72); ADOPTING MINOR AMENDMENTS TO PROMOTE CLARITY, ELIMINATE REDUNDANCY, AND CORRECT INCONSISTENCIES PURSUANT TO CHAPTER 161 KZC.

WHEREAS, the City Council has received from the Kirkland Planning Director a recommendation to amend certain sections of the text of the Kirkland Zoning Code, Ordinance 3719 as amended, all as set forth in that certain report and recommendation of the Planning Director dated March 12, 2002 and bearing Kirkland Department of Planning and Community Development File No. IVA-01-72; and

WHEREAS, pursuant to the City of Kirkland's Concurrency Management System, KMC Title 25, this action is exempt from the concurrency management process; and

WHEREAS, prior to making said recommendation, the Planning Director, following notice thereof as required by RCW 35A.63.070, on November 26, 2001, held a public hearing on the amendment proposals and considered the comments received at said hearing; and

WHEREAS, pursuant to the State Environmental Policies Act there has accompanied the legislative proposal and recommendation through the entire consideration process, a final determination of nonsignificance, including supporting environmental documents, issued by the responsible official pursuant to WAC 197-11-340 and WAC 197-11-390; and

WHEREAS, in regular public meeting the City Council considered the environmental documents received from the responsible official, together with the report and recommendation of the Planning Director.

NOW, THEREFORE, BE IT ORDAINED by the City Council of the City of Kirkland as follows:

Section 1. The following specified sections of the text of Ordinance 3719 as amended, the Kirkland Zoning Ordinance, be and they hereby are amended as follows:

Delete Section 50.65, Design Regulations for the Central Business District and Section 52.50, Design Regulations for the Juanita Business District. These sections are to be replaced with Chapter 92, Design Regulations. Chapter 92 and minor amendments to other parts of the Zoning Code text are set forth in Attachment A, which by this reference is incorporated herein.

Section 2. If any section, subsection, sentence, clause, phrase, part or portion of this ordinance, including those parts adopted by reference, is for any reason held to be invalid or unconstitutional by any court of competent jurisdiction, such decision shall not affect the validity of the remaining portions of this ordinance.

Section 3. This ordinance shall be in full force and effect five days from and after its passage by the Kirkland City Council and publication, pursuant to Section 1.08.017 Kirkland Municipal Code, in the summary form attached to the original of this ordinance and by this reference approved by the City Council, as required by law.

Section 4. A complete copy of this resolution, including Findings, Conclusions and Recommendations adopted by reference, shall be certified by the City Clerk, who shall then forward the certified copy to the King County Department of Assessments.

PASSED by majority vote of the Kirkland City Council in regular, open meeting this 19th day of March, 2002.

SIGNED IN AUTHENTICATION thereof this 19th day of March, 2002.

  
\_\_\_\_\_  
Mayor

Attest:

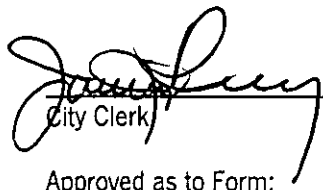
  
\_\_\_\_\_  
City Clerk

Approved as to Form:

  
\_\_\_\_\_  
City Attorney

**Chapter 92 - DESIGN REGULATIONS**

## Sections:

- 92.05 Introduction
1. General
  2. Applicability
  3. D.R. Procedures
  4. Landscaping
  5. Dedication
- 92.10 Pedestrian-Oriented Elements
1. Installation of Sidewalks
  2. Required Major Pedestrian Pathways
  3. Pedestrian-Oriented Elements Provisions Supersede
  4. Through-Block Sidewalks in the JBD
  5. Pedestrian Weather Protection
  6. Building Frontage
  7. Access to Buildings
  8. Pedestrian-Oriented Space and Plazas
  9. Blank Wall Treatment
  10. Treatment of Building Facades
  11. Screening of Certain Areas
- 92.15 Entry Features in the JBD
- 92.20 Public Improvements and Site Features
1. Public Improvement and Site Feature Standards and Masterplan for Public Property
  2. On-Site Improvements
- 92.25 Parking Area Location and Design
1. Location of Parking Lots
  2. Parking Lot Entrances and Driveways
  3. Parking Lot Pedestrian and Vehicular Access
  4. Internal Parking Lot Landscaping
  5. Perimeter Parking Lot Landscaping
  6. Perimeter Parking Lot Landscaping – Adjacent Properties
  7. Parking Garages
  8. Miscellaneous Parking Area Design Details

92.30

## Scale

1. Techniques to Moderate Bulk and Mass in the CBD
2. Achieving Human Scale
3. Techniques to Achieve Architectural Scale

92.35

## Building Material, Color and Detail

1. Required Elements
2. Prohibited Materials
3. Metal Siding
4. Concrete Block
5. Awnings
6. Covering of Existing Facades
7. Building Cornerstone or Plaque
8. Building Corners in the CBD

92.05

Introduction

1. General – This chapter establishes the design regulations that apply to development in both the Central Business District (CBD) and Juanita Business District (JBD). Special provisions that apply to only the CBD or the JBD are noted in the margins and text of the chapter.
2. Applicability – The provisions of this chapter apply to all new development. The provisions of Chapters 142 and 162 KZC regarding Design Review (D.R.) and nonconformance establish which of the regulations of this chapter apply to developed sites. Where provisions of this chapter conflict with provisions in any other section of the code, this chapter prevails.
3. D.R. Procedures – The City will use Chapter 142 KZC to apply the regulations of this chapter to development activities that require D.R. approval.
4. Landscaping – Various places in this chapter require that landscaping be installed and maintained. The following provisions apply to the installation and maintenance of all landscaping, including street trees, installed under the provisions of this chapter unless otherwise specifically indicated:
  - a. At the time of planting, deciduous trees must be three to four inches in diameter, as measured using the standard of the American Association of Nurserymen, and coniferous trees must be six to eight feet in height at the time of planting.
  - b. Shrubs must be 18 inches high at the time of planting.
  - c. Drought-tolerant plants are encouraged.
  - d. The City will review plant choice and specific plant location as part of the D.R. approval. The City may also require or permit modification to the required plant size as part of D.R. approval. Where appropriate, the City

will apply the provisions of KZC 95.20(2)(c) to require additional or more mature landscaping.

5. Dedication – The City may require the applicant to dedicate development rights, air space, or an easement to the City to ensure compliance with any of the requirements of this chapter.

## 92.10

Pedestrian-Oriented Elements

This section contains regulations that require various pedestrian-oriented elements on or adjacent to the subject property.

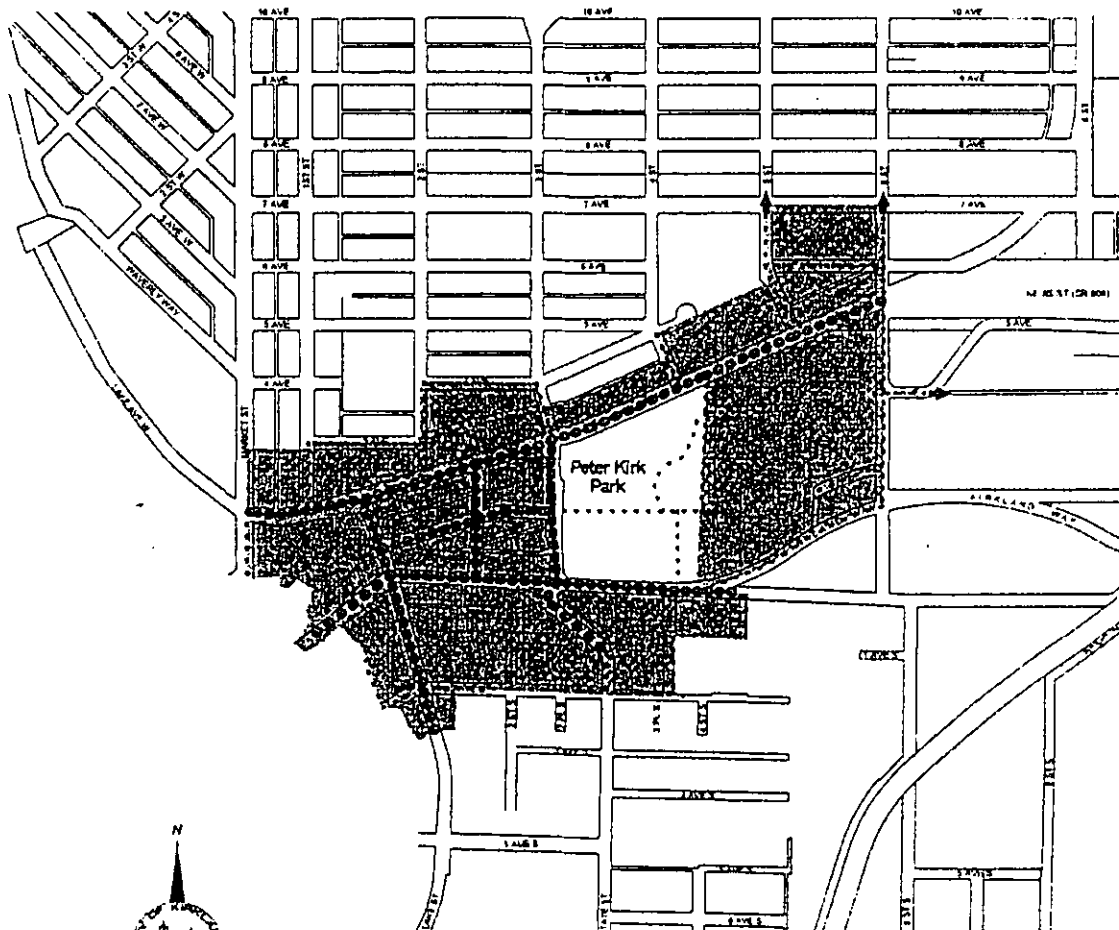

1. Installation of Sidewalks – The applicant shall install a sidewalk constructed of concrete or unit pavers, at least 10 feet in width (or as specified in the public improvement and site feature master plan), along the entire frontage of the subject property adjacent to each *pedestrian-oriented street*. If the required improvements can't be accommodated within the existing right-of-way, the difference may be made up with a public easement over private property. Buildings may cantilever over such easement areas, flush with the property line (see Figures 92.10.A, B and C).
2. Required Major Pedestrian Pathways – If the subject property abuts a street designated to contain a major pedestrian pathway on Figure 92.10.A or Figure 92.10.B, the applicant shall install that pathway on and/or adjacent to the subject property consistent with the following standards:
  - a. The major pedestrian pathways must be installed in the approximate location shown on Figure 92.10.A and Figure 92.10.B and make the connections shown on the figures.
  - b. The major pedestrian pathways must be paved with concrete or unit pavers and have a minimum width of at least eight feet, unless otherwise noted in Figure 92.10.A. If the required improvements can't be accommodated within the existing right-of-way, the difference may be made up with a public easement over private property. Buildings may cantilever over such easement areas, flush with the property line.
  - c. The major pedestrian pathways must have adequate lighting with increased illumination around building entrances and transit stops.
  - d. If parcels are developed in aggregate, then alternative solutions may be proposed.
3. Pedestrian-Oriented Elements Provisions Supersede – If the provisions of KZC 92.10.1 and KZC 92.10.2 of this chapter both apply to improvements within and/or adjacent to a street, the provisions of KZC 92.10.1, and not KZC 92.10.2, must be followed.

# Pedestrian Circulation in the CBD



400 0 400 800 Feet

### Legend

-  Pedestrian-Oriented Street
-  Major Pedestrian Pathway
-  Central Business District

Note: The Lakefront Boardwalk (see downtown master plan in Comprehensive Plan) may vary in width from the eight feet required for major pedestrian pathways.

FIGURE ~~92.10.A~~

92.10.A

# Pedestrian Circulation in the JBD

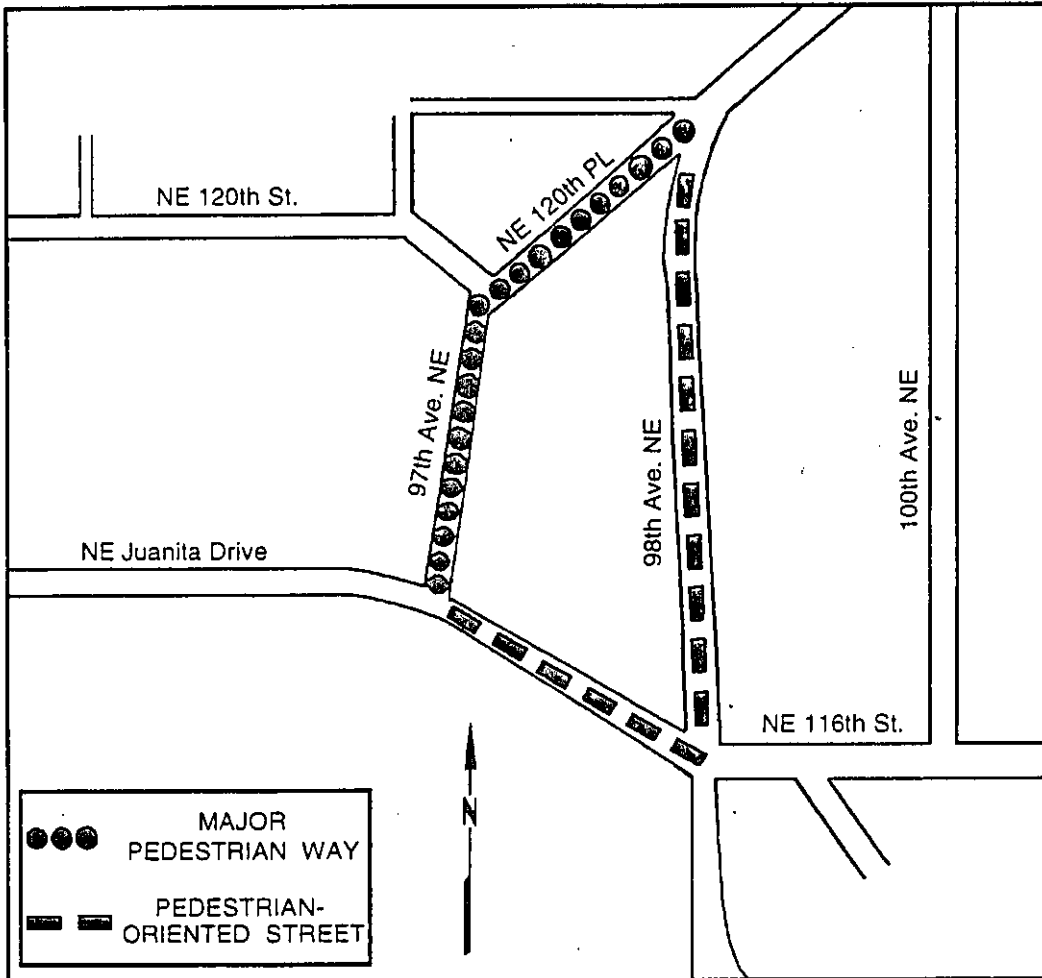

FIGURE 92.10 B

### Required Sidewalk on Pedestrian-Oriented Streets and Major Pedestrian Ways

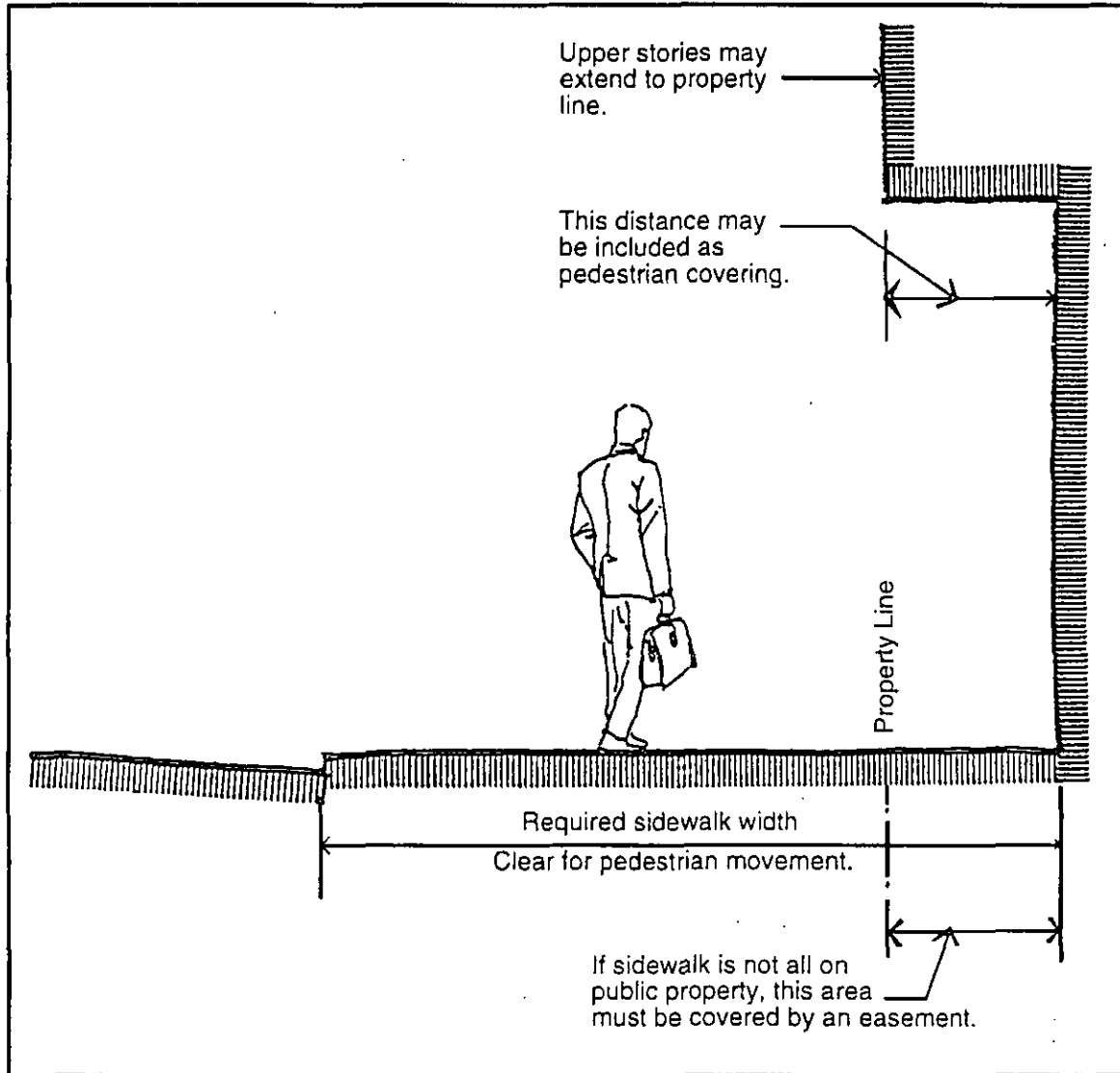

FIGURE 92.10.C



**JBD**

4. Through-Block Sidewalks in the JBD – The applicant shall install a through-block sidewalk extending from the north end to the south end of JBD 1 of the Juanita Business District. Two through-block sidewalks, spaced far enough apart to provide maximum accessibility for the whole block, will also extend from the east side to the west side of JBD 1.

The alignment of these sidewalks will take into account proposed and existing buildings and, to the extent possible, will extend along building fronts or property lines.

- a. The applicant must install sidewalks that run generally north/south (or diagonally northeast/southwest) and east/west on the subject property. The sidewalks shall be located to provide a direct continuation of the existing or future through-block sidewalk on adjacent properties. When possible, the sidewalks shall be located to create view corridors and reinforce connections to Lake Washington. During the D.R. process, the City may determine that a through-block sidewalk is not required if a suitable sidewalk exists on adjacent properties.
- b. Through-block sidewalks adjacent to the front of buildings must be 10 feet wide with a six-inch vertical curb, and paved with concrete or unit pavers. Sidewalks that are not adjacent to the front of buildings must have a minimum width of eight feet and be differentiated from underlying pavement with texture or material, unless otherwise determined through D.R.
- c. The through-block sidewalks must have adequate lighting with increased illumination around building entrances and transit stops.
- d. If parcels are developed in aggregate, then alternative solutions may be proposed.
- e. Barriers that will limit pedestrian access between the subject property and adjacent properties are not permitted.

5. Pedestrian Weather Protection – The applicant shall provide overhead weather protection, consistent with the following standards:

**CBD**

- a. In the CBD, along at least 80 percent of the frontage of the subject property on each pedestrian-oriented street;

**JBD**

- b. In the JBD, along 100 percent of the front of the building;
- c. The overhead weather protection may be composed of awnings, marquees, canopies or building overhangs;
- d. It must cover at least five feet of the width of the sidewalk. The width may vary (not less than three feet) to accommodate street trees, streetlights, etc.
- e. The lowest element of the overhead weather protection must be at least eight feet above the ground immediately below it;
- f. The City will specifically review and approve the color, material and configuration of all overhead weather protection as part of the D.R. decision. See also KZC 92.35.5, Awnings.

- JBD** 6. Building Frontage – In the JBD, all buildings must front on a right-of-way or through-block sidewalk.
- CBD** 7. Access to Buildings:
- a. In the CBD, all buildings on property abutting *pedestrian-oriented streets* must have direct access from the sidewalk of the *pedestrian-oriented street* to the main building entrance.
- JBD** b. In the JBD, all buildings must have convenient access from the street sidewalk or the through-block sidewalk to the main building entrance.
- CBD** 8. Pedestrian-Oriented Space and Plazas – In the CBD, if the subject property abuts a *pedestrian-oriented street* or public park, the space, if any, between the sidewalk and the building must be developed consistent with the following criteria:
- a. It must:
- 1) Enhance visual and pedestrian access, including handicapped access, onto the subject property from the sidewalk.
  - 2) Contain paved walking surface of either concrete or approved unit pavers.
  - 3) Contain on-site or building-mounted lighting, which provides adequate illumination.
  - 4) Contain two linear feet of seating area or one individual seat per 65 square feet of area between the sidewalk and the building.
  - 5) Contain landscaping, such as trees, shrubs, trellises, or potted plants.
- b. It may not include asphalt or gravel pavement or be adjacent to an unscreened parking area, a chain link fence or a blank wall, which does not comply with the requirements of KZC 92.10.10 of this chapter.
9. Blank Wall Treatment
- a. Each wall or portion of a wall that is closer than 50 feet to any exterior property line of the subject property and is visible from any right-of-way must be screened or treated in at least one of the ways listed in KZC 92.10.9.c if it meets the criteria for a blank wall under KZC 92.10.9.b of this section.
- b. A blank wall is any wall or portion of a wall that meets either of the following criteria (see Figure 92.10.D):
- 1) A wall or portion of a wall with a surface area of at least 400 square feet having both a length and a width of at least 10 feet without a window, door, building modulation at least one foot in depth or other architectural feature.
  - 2) Any wall or portion of a wall between four feet and 13 feet above ground level with a horizontal dimension longer than 15 feet without a

### Designating Blank Walls

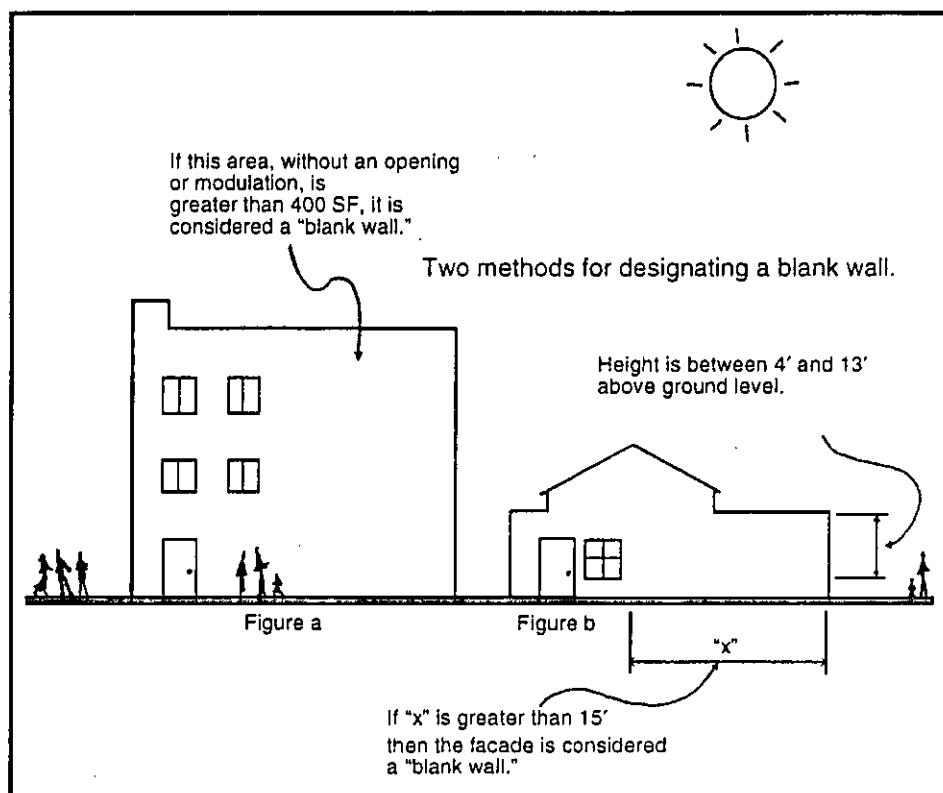

FIGURE ~~92.10.D~~ 92.10.D

window, door, building modulation at least one foot in depth or other architectural feature.

- c. At least one of the following techniques must be used to treat or screen blank walls:
  - 1) By the installation of a vertical trellis with climbing vines or plant material in front of the blank wall.
  - 2) By providing a landscaped planting bed at least five feet wide or a raised planter bed at least two feet high and three feet wide in front of the blank wall and planted with plant materials that will obscure or screen at least 50 percent of the blank wall within two years.
  - 3) By providing artwork, such as mosaics, murals, sculptures or bas-relief on the blank wall.
  - 4) By proposing alternative techniques as part of D.R.
- d. The provisions of section KZC 92.10.9 may be modified or eliminated as part of the D.R. decision if they conflict with the Uniform Building Code.

#### **CBD**

- 10. Treatment of Building Facades – In the CBD, each facade of a building facing a *pedestrian-oriented street* or public park must contain or be treated with at least one of the following elements:
  - a. It must contain transparent windows or window displays comprising at least 75 percent of the area of the facade between two feet and seven feet above ground level (see Figure 92.10.E).
  - b. It must contain sculptural, mosaic or bas-relief artwork comprising at least 75 percent of the area of the facade between two feet and seven feet above ground level (see Figure 92.10.E).
  - c. The area next to the facade must be developed such that for every 10 linear feet of the facade, at least 20 square feet of this area must be developed with landscaping consistent with KZC 92.10.9.c.1) or 2), depending on the location, dimensions, and size of the area.
- 11. Screening of Certain Areas – All loading areas, service areas, outdoor storage areas of more than 100 square feet; areas containing waste storage and disposal facilities or containers; and similar areas must be:
  - a. Located on the subject property so that they are not visible from any street, through-block sidewalk, or public park. If the City determines that this is not physically possible, then these areas must be screened from public view using a compact evergreen hedge, a solid wall or fence, or in a manner approved by the City as part of the D.R. decision.
  - b. Screened from on-site ground floor uses using a compact evergreen hedge, a solid wall or fence, or in a manner approved by the City as part of the D.R. decision.

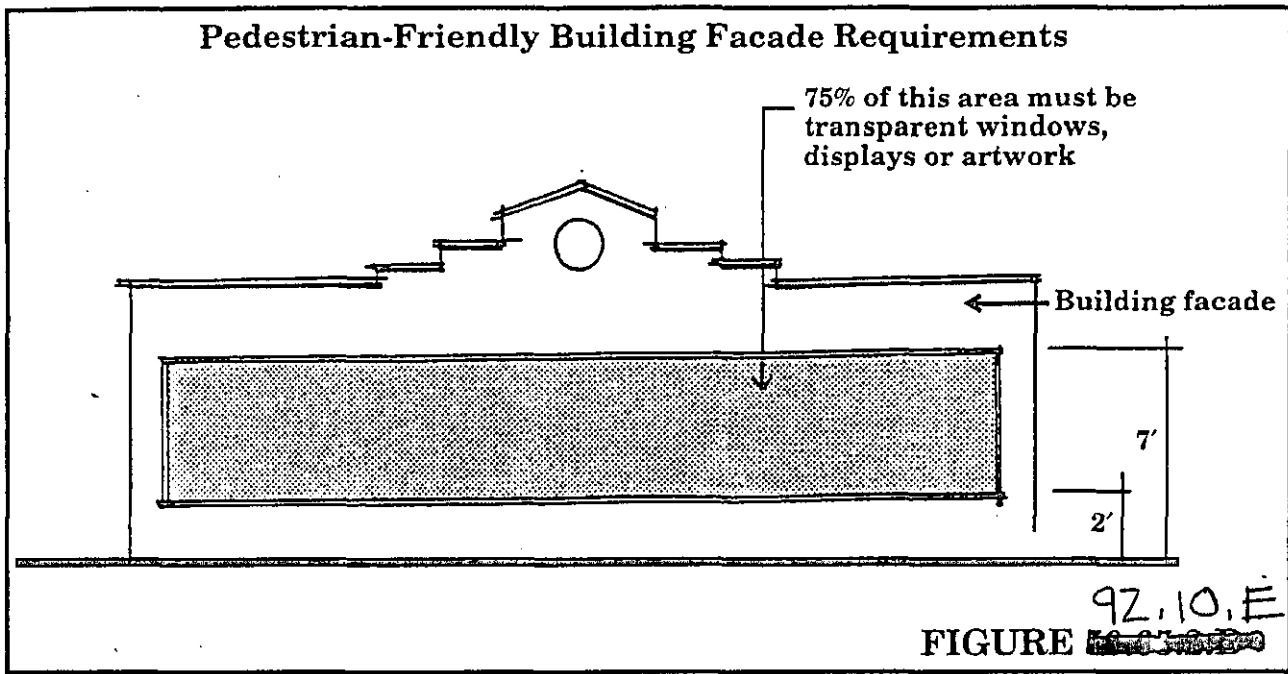

92.15 Entry Features in the JBD**JBD**

In the JBD, if the subject property includes an area designated for an entry feature in the Comprehensive Plan or design guidelines, the applicant shall provide the City with a publicly maintained easement or dedication of property for this purpose. The size of the entry feature area will be at least 100 square feet. The applicant shall propose and install landscaping for the area that will be reviewed by the City and decided upon as part of the design review for the proposed development.

92.20 Public Improvements and Site Features

1. Public Improvement and Site Feature Standards and Masterplan for Public Property
  - a. The Public Works Director in consultation with the Planning Director, shall administratively adopt and publish public improvement and site feature standards for the placement, installation, construction and maintenance of the following features to be constructed on and adjacent to major pedestrian pathways, streets, alleys and public parks:
    - 1) Street trees and street tree grates.
    - 2) Landscape plant materials.
    - 3) Paving materials.
    - 4) Lighting fixtures for streets, pedestrian areas and special areas.
    - 5) Public signs.
    - 6) Benches and seating areas.
    - 7) Trash receptacles.
    - 8) Drinking fountains.
    - 9) Sidewalk widths and details.
    - 10) Bicycle racks.
    - 11) Bollards.
    - 12) Crosswalks.

Until the public improvement and site feature standards are adopted and published, the City shall, as part of the D.R. decision, specifically review and approve the placement, installation, construction and maintenance of these features.
  - b. The City shall adopt a masterplan for public spaces. The master plan shall discuss the placement of the features noted in KZC 92.20.3.a of this section, present a long-range and coordinated plan for public property, and further implement the Downtown Plan Chapter and the JBD Plan provisions of the Comprehensive Plan.
  - c. Once adopted and published, the City may allow departure from the public improvement and site feature standards or the masterplan as part of the D.R. approval where compliance with those standards or

masterplan is not feasible or where major development warrants special design emphasis.

2. On-Site Improvements

- a. Mixed use centers, residential projects and office buildings shall provide bicycle racks that are conveniently located for bicyclist use and provide secure storage for bicycles.
- b. Water spigots shall be provided on all building facades along sidewalks for cleaning and plant watering.

92.25 Parking Area Location and Design – This section regulates the location and design of, access for and other features of parking areas.

**CBD**

1. Location of Parking Lots

- a. In the CBD:
  - 1) On *pedestrian oriented streets*, parking lots shall not be located between the *pedestrian-oriented street* and a building unless specified in the public improvement and site feature masterplan.
  - 2) On all other streets, parking lots shall not be located between the street and the building on the subject property unless no other feasible alternative exists.

**JBD**

- b. In JBD 2, parking lots shall not be located between the street and the building unless no other feasible alternative exists on the subject property.

2. Parking Lot Entrances and Driveways – As part of D.R., the City may impose additional restrictions on the width, number and location of driveways to and from the subject property to improve vehicle circulation or public safety or to enhance pedestrian movement or desirable visual characteristics. Parking lot entrances and driveways must be shared between properties whenever possible.

3. Parking Lots - Pedestrian and Vehicular Access

- a. Any property adjacent to a right-of-way or park must contain a pedestrian walkway from the right-of-way or park to the main entrance of the building or to a central location if the building has multiple entrances, even if this walkway must cross a parking lot (see Figure 92.25.A).
- b. As determined through D.R., the walkway shall be:
  - 1) Centrally located within the parking lot.
  - 2) Delineated by painted markings, distinctive pavement, or by being raised six inches above the parking lot pavement.
  - 3) At least five feet wide.
  - 4) Handicapped accessible.

### Pedestrian Walkway

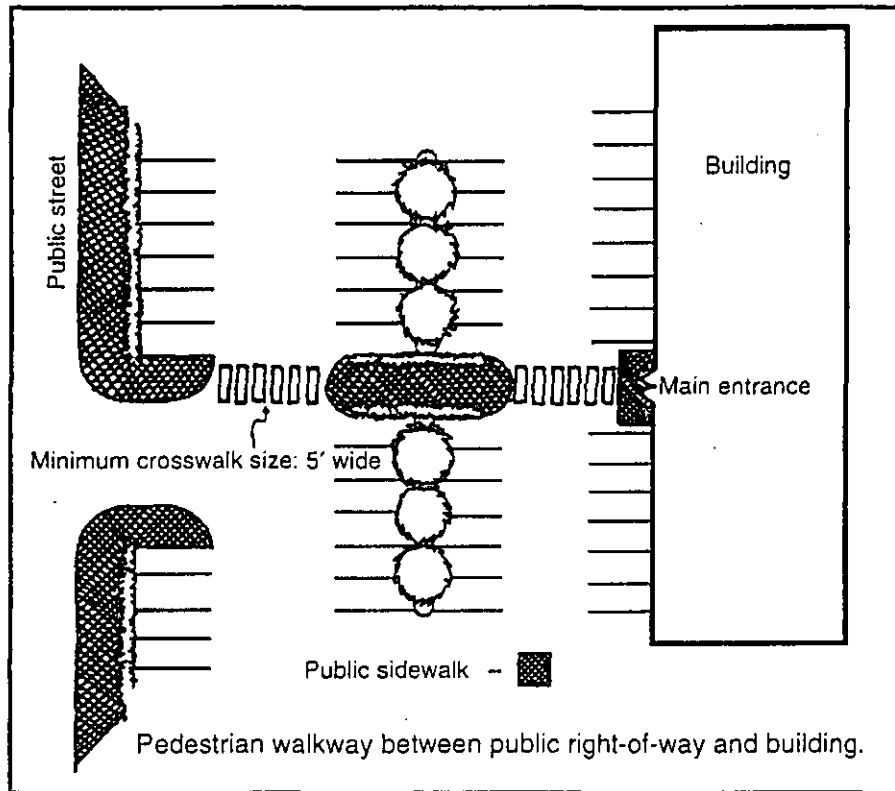

FIGURE ~~92.25.A~~ 92.25.A



- c. All parking lots which contain more than 25,000 square feet of paved area, including access lanes and driveways, must include clearly identified pedestrian routes from the parking stalls to the main building entrance or central location.
  - d. In addition to the walkways required under KZC 92.25.3.a and KZC 92.25.3.c of this section, the applicant must provide a sidewalk, plaza or platform with an area of at least 175 square feet at the main building entrance or central location. This area must be raised at least six inches above the parking lot surface and must be paved with concrete or unit pavers.
  - e. Convenient pedestrian access must be provided on the subject property to adjacent properties. Barriers which will limit future pedestrian and vehicular access are not permitted.
4. Internal Parking Lot Landscaping – The following provisions apply to each parking lot or portion thereof containing more than 14 parking stalls within 100 feet of a street, through-block sidewalk or public park. The provisions do not apply to parking lots that are not visible from a street, through-block sidewalk or public park.
- a. The parking lot must contain 25 square feet of landscape area per parking stall planted as follows (see Figure 92.25.B):
    - 1) At least one tree for every six parking stalls.
    - 2) At least one shrub for every 20 square feet of landscaped area. Up to 50 percent of the shrubs may be deciduous.
    - 3) Groundcover shall be selected and planted to achieve 90 percent coverage within two years.
    - 4) The location of the landscaping will be reviewed through D.R.
  - b. As part of the D.R., the City may require or permit a modification to the provisions of KZC 92.25.4.a of this section to use existing vegetation for internal parking lot landscaping.
5. Perimeter Parking Lot Landscaping – Each side of a parking lot that abuts a street, through-block sidewalk or public park must be screened from that street, through-block sidewalk or public park using one or a combination of the following methods:
- a. By installation of a compact evergreen hedge or wall consistent with the following standards as applicable (see Figure 92.25.C):
    - 1) The hedge or wall must extend at least two feet, six inches, and not more than three feet above the ground directly below it.
    - 2) The wall may be constructed of masonry or concrete, if consistent with the provisions of KZC 92.35.1.g.1), in Building Material, Color, and Detail, or of wood if the design and materials match the building on the subject property.

### Internal Parking Lot Landscaping

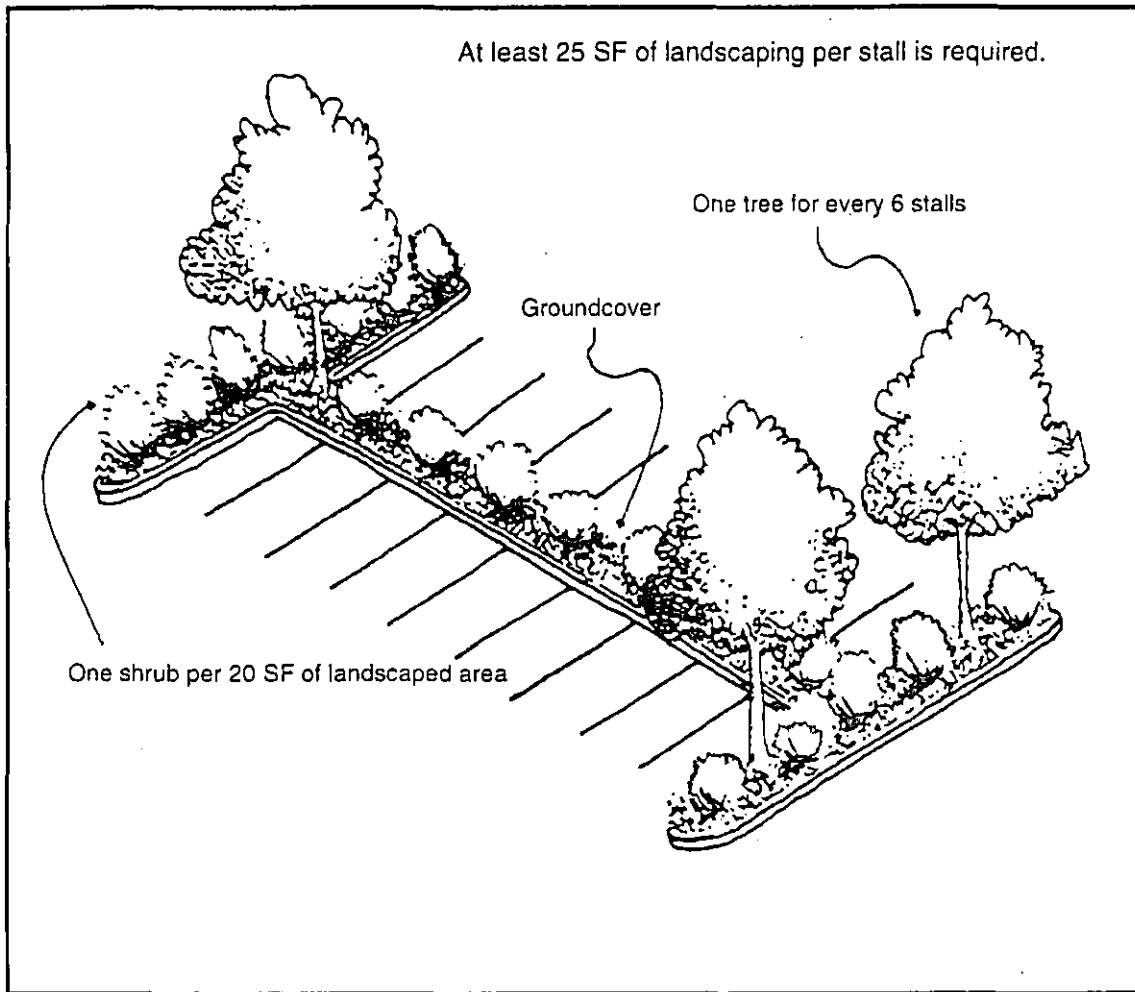

FIGURE ~~92.25.A~~  
92.25.B

Trellis, grillwork, or pedestrian covering. Planted vines or hanging flowers are encouraged.

2' 6" to 3' 0"

Sidewalk

5' min

Brick or masonry to match building material if possible

Constructed screen wall option for perimeter landscaping.

### Examples of Various Screen Wall Designs

Architectural elements should complement facade design

— Lighting is encouraged

Wrought iron or strap steel grill

Concrete or stucco to match building material —

Vines and landscaping are encouraged

Planter

Approved sign

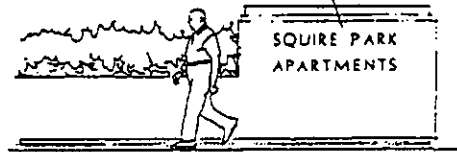
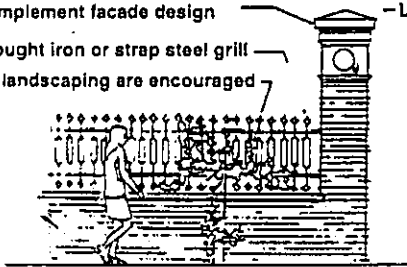

Traditional

Contemporary

Pedestrian covering is encouraged —

Ornamental light

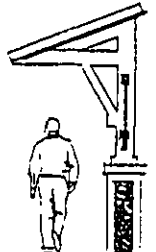
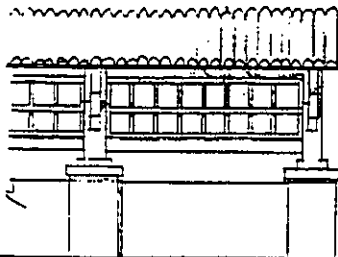

Colored tile

Pipe railing

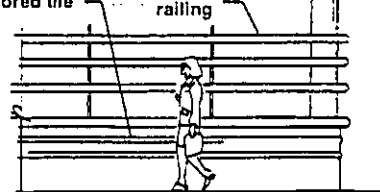

Mission Style with Canopy

Deco-Moderne Style

FIGURE ~~92.25.C~~

JBD

- 3) In the JBD, if the street is a *pedestrian-oriented street*, the wall may also include a continuous trellis or grillwork, at least five feet in height above the ground, placed on top of or in front of the wall and planted with climbing vines consistent with KZC 92.05.4, Landscaping. The trellis or grillwork may be constructed of masonry, steel, cast iron and/or wood.

JBD

- 4) In the JBD, if the wall abuts a *pedestrian-oriented street*, the requirements of this subsection may be fulfilled by providing pedestrian weather protection along at least 80 percent of the frontage of the subject property.
  - b. By providing a landscaped strip, consistent with KZC 92.05.4, Landscaping, at least five feet wide planted as follows (see Figure 92.25.D):
    - 1) Trees planted 30 feet or closer on center.
    - 2) At least one shrub for every 20 square feet of landscaped strip.
    - 3) Groundcover selected and planted to achieve 90 percent coverage of the remaining landscaped strip within two years.
  - c. As part of D.R., the City may require or permit a modification to the provisions of KZC 92.25.5.b to use existing vegetation for perimeter parking lot landscaping.
6. Perimeter Parking Lot Landscaping – Adjacent Properties – Each side of the perimeter of a parking lot containing more than 14 parking stalls, that is within 10 feet of any adjacent property and that is not regulated under the provisions of KZC 92.25.6, Perimeter Parking Lot Landscaping, shall be screened using a combination of the following methods:
  - a. By installing a solid, continuous fence or wall at least five feet in height constructed of wood and/or masonry.
  - b. By installing a compact evergreen hedge designed to reach at least five feet in height.
  - c. As part of D.R., the City may require or permit a modification to the provisions of this subsection for any side of the parking lot that abuts or is connected to a parking lot on an adjacent property if the parking lots have internal vehicular or pedestrian connections.
7. Parking Garages
  - a. Each facade of a garage or a building containing ground floor parking must either:

### Shrub and Trees Option for Perimeter Parking Lot Landscaping

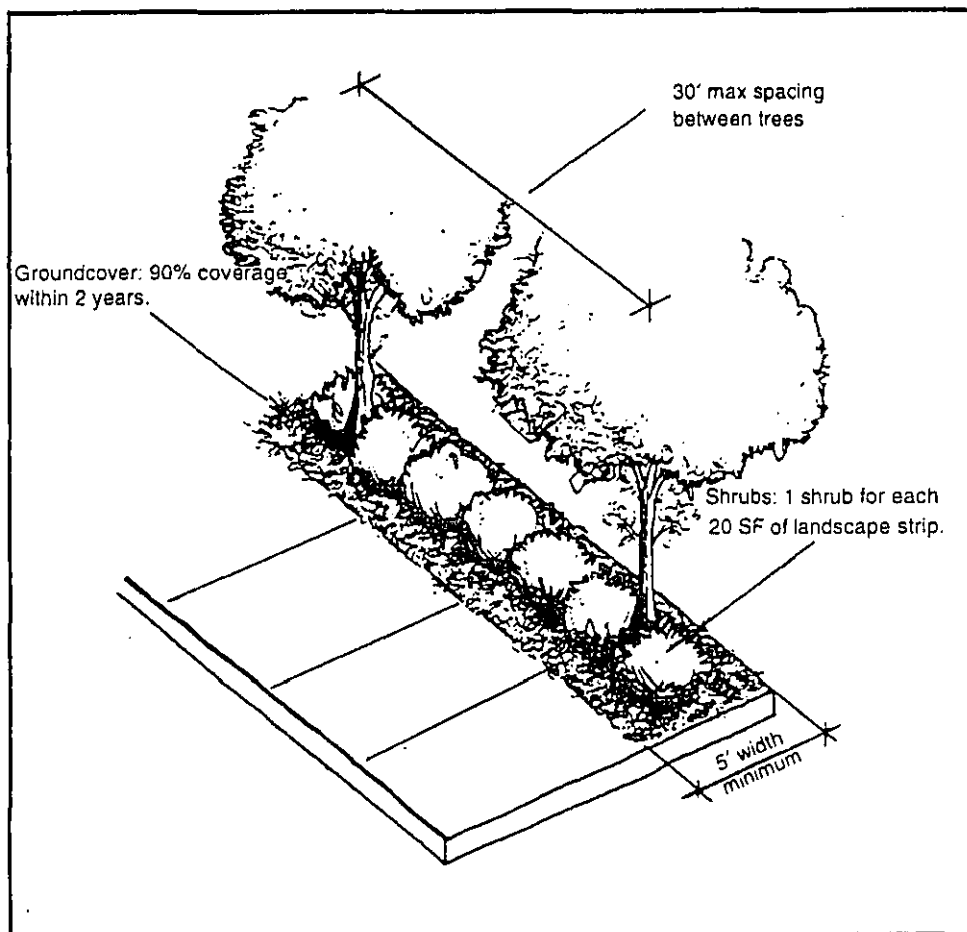

FIGURE 92.25.D

- 1) Provide and maintain a ground floor area of the garage or building extending along the entire facade of the garage or building (excluding vehicle access points) which is developed as and made available for pedestrian-oriented businesses (see Figure 92.25.E);
  - 2) Provide and maintain a pedestrian-oriented space, consistent with the standards of KZC 92.10.8 of this chapter, at least 10 feet in depth and extending along the entire facade of the garage or building (excluding vehicle access points); or
  - 3) Treat the facade consistent with KZC 92.10.10.a, b, or c, Treatment of Building Facades.
- b. There must be architectural screening or other treatment of openings above the ground level for the facades of parking garages along pedestrian-oriented streets or through-block sidewalks.
  - c. All parking garages and parking within a structure must contain designated pedestrian walkways that:
    - 1) Do not use vehicle entrance or exit driveways, from the parking area to a public right-of-way; and
    - 2) Go from the parking spaces to the pedestrian entrance of the building served by the parking.
8. Miscellaneous Parking Area Design Details
- a. All parking areas must have adequate lighting. Lights in parking lots must be nonglare and must be mounted no more than 20 feet above the ground.
  - b. All landscape and pedestrian areas shall be protected from encroachment by parked cars. At a minimum, the parking area must be designed and constructed so car wheels are kept at least two feet from landscape and pedestrian areas. Freestanding wheel-stop bumpers must be replaced or repaired if cracked or broken (see Figure 92.25.F).
  - c. No freestanding or wall-mounted signs for individual parking spaces are permitted to extend more than three feet above the ground. Provisions in the UBC for handicapped stalls supersede this requirement.
  - d. Moveable parking area equipment, such as barrels and sawhorses, may not be visible from a street when not in use. Parking areas and accessory components, areas and facilities must be well-maintained and kept in a clean, neat and litter-free manner at all times.

92.30

Scale**CBD**

1. Techniques To Moderate Bulk and Mass in the CBD
  - a. General ~ This section establishes required techniques to be used in the design and construction of building facades in specific areas of the CBD. The applicant shall comply with the techniques listed below in order to reduce the perceived bulk and mass of large structures by dividing the

### Providing Space for Pedestrian-Oriented Business

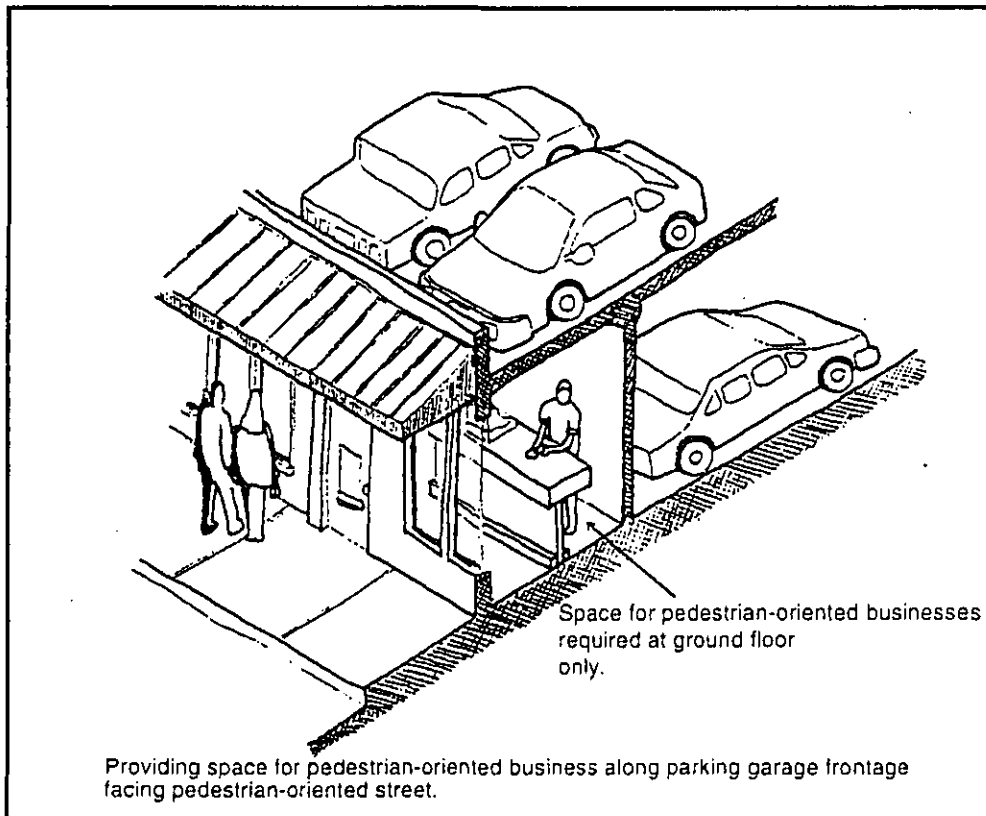

FIGURE ~~92.25~~ 92.25.E

### Extended Curb Used To Protect Landscape Strip

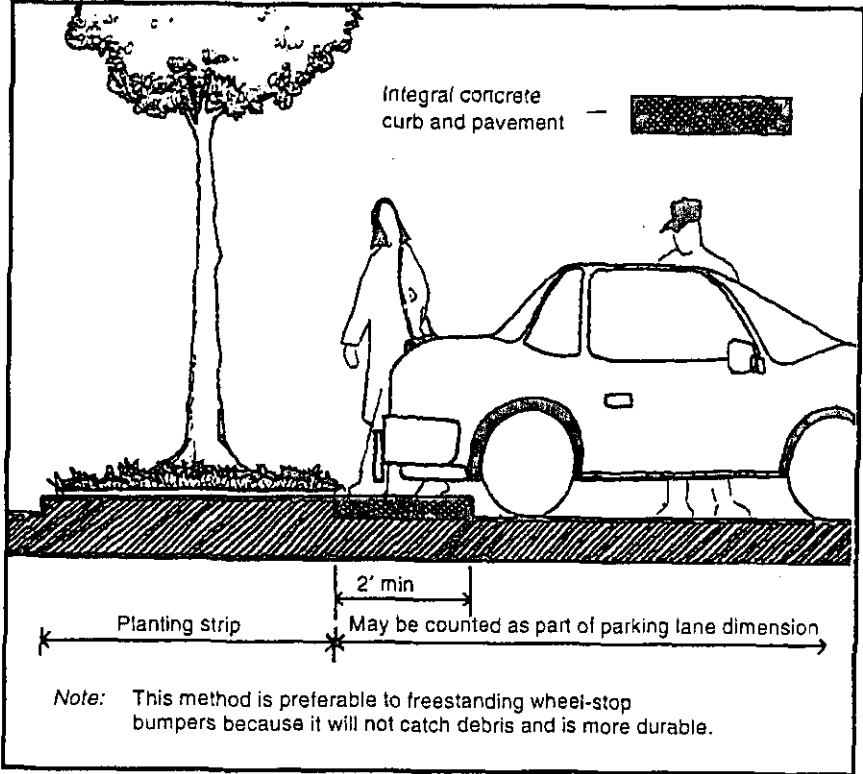

FIGURE 92.25.F



building mass into smaller-scale components. As an alternative, the City may approve other techniques, elements, or methods proposed by the applicant, if they are consistent with the following criteria:

- 1) The alternative is generally consistent with the Downtown Plan provisions of the Comprehensive Plan and the design guidelines.
  - 2) The alternative clearly provides superior moderation of the architectural bulk and mass than would result from strict application of the required techniques.
- b. Vertical Definition – The applicant shall comply with the following requirements to moderate the horizontal scale of buildings:
- 1) All Zones – The maximum length of any facade facing a street is 70 feet without vertical definition. Vertical definition may be in the form of changes in color and materials, modulations of sufficient width and depth to define the vertical element, or some combination of these techniques. This vertical element should carry through all floors of the building.
  - 2) CBD 4, CBD 6, CBD 8 – Along First Street, Second Street South, First Avenue South, and Fifth Street, the maximum length of a facade is 120 feet. Any facade that exceeds 120 feet along the right-of-way shall comply with the following requirements (see Figure 92.30.A):
    - a) Shall be divided by a 30-foot-wide modulation of the exterior wall so the maximum length of the facade is 120 feet without this modulation.
    - b) The modulation shall be 20 feet in depth and shall start at finished grade and extend through all floors.
    - c) Decks and roof overhangs may encroach up to three feet (per side) into the modulation.
  - 3) CBD 6, CBD 8: Along the axes of all buildings that are predominantly east-west and/or most closely parallel to Central Way, Third Avenue, Fourth Avenue, or Sixth Avenue, the maximum length of a building is 120 feet. The following exceptions apply (see Figure 92.30.B):
    - a) Portions of buildings, that are below the elevation of Third Avenue, Fourth Avenue, or Sixth Avenue, as measured at the midpoint of the frontage of the subject property on the applicable right-of-way, may exceed the 120-foot limitation.
    - b) Portions of buildings that are above Third Avenue, Fourth Avenue, or Sixth Avenue shall be divided into two or more distinct building masses with a maximum length of 120 feet separated by at least 20 feet in width.
    - c) Decks, bay windows, roof overhangs, and chimneys may encroach up to three feet (per side) into the separation.

Vertical Definition: CBD 4, 6, and 8

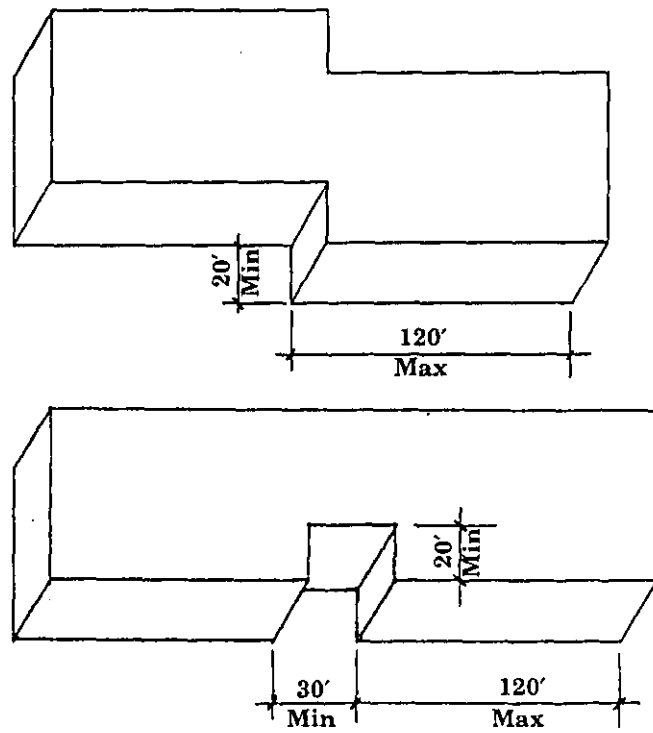

FIGURE ~~506-3001~~

92.30.A

Vertical Definition: CBD 6 and 8

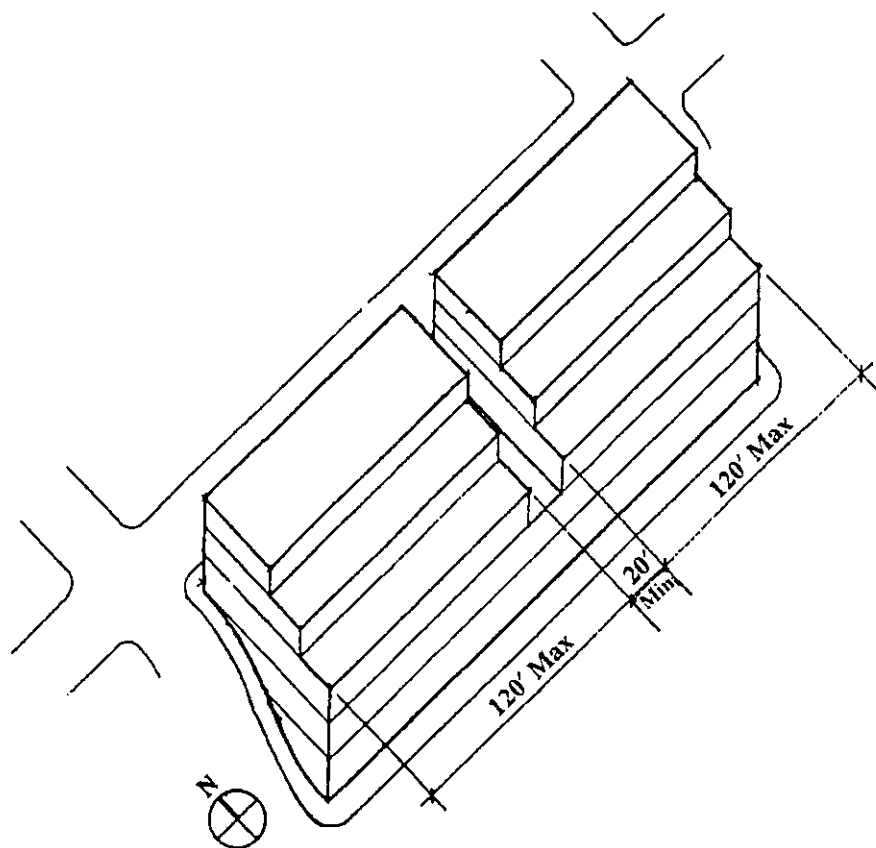

FIGURE ~~90.30.B~~  
92.30.B

- c. Horizontal Definition – The applicant shall comply with the following requirements to moderate the vertical scale of buildings. All buildings in the CBD shall include design techniques, which clearly define the building's top, middle, and bottom (See Figure 92.30.C). The following techniques are suggested methods of achieving vertical articulation:
- 1) Top: Sloped roofs, strong eave lines, cornice treatments, horizontal trellises, or sunshades, etc.
  - 2) Middle: Windows, balconies, material changes, railings, and similar treatments that unify the building design.
  - 3) Bottom: Pedestrian-oriented storefronts, pedestrian scale building details, awnings, arcades, "earth" materials such as concrete stone, stucco, etc.
- Where appropriate, the applicant should coordinate the horizontal elements (i.e., cornices, window lines, arcades, etc.) in a pattern and height to reflect similar elements on neighboring buildings.

## 2. Achieving Human Scale

**CBD**

### a. General

1) CBD: Except as provided in KZC 92.30.2.a.3) of this section, the applicant shall use at least two of the elements or techniques listed in KZC 92.30.2.b of this section in the design and construction of each facade of a building facing a street or public park.

**JBD**

2) JBD: Except as provided in KZC 92.30.2.a.3) of this section, the applicant shall use at least one of the elements or techniques listed in KZC 92.30.2.b of this section in the design and construction of each facade of a one-story building facing a street or through-block sidewalk, and at least two of the elements or techniques for a two-story building facing a street or through-block sidewalk.

3) The applicant shall use at least three of the elements or techniques listed in KZC 92.30.2.b of this section in the design and construction of any facade of a building facing a street or public park, if:

- a) The facade has a height of three or more stories; or
- b) The facade is more than 100 feet long.

b. Techniques To Achieve Human Scale – The techniques to be used in the design and construction of building facades under KZC 92.30.2.a of this section are listed below. As an alternative, the applicant may propose other techniques, elements or methods that provide human scale to the building and are consistent with the applicable design guidelines and the Comprehensive Plan.

1) On each story above the ground floor, provide balconies or decks, at least six feet wide and six feet deep.

### Horizontal Definition: Articulation of Buildings' Top, Middle, and Bottom

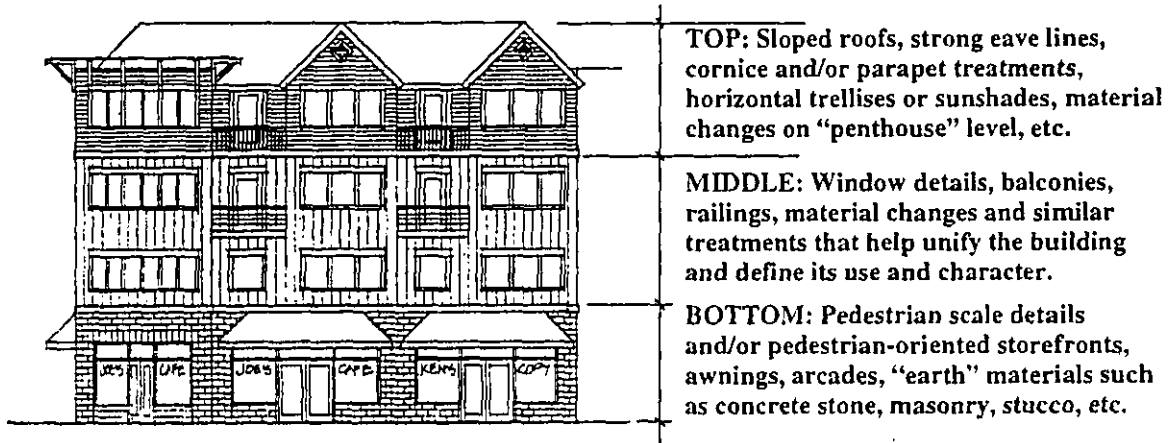

FIGURE ~~92.30 C~~

92.30 C

- 2) On each story above the ground floor, provide bay windows that extend out at least one foot, measured horizontally, from each facade of the building.
  - 3) Provide at least 150 square feet of pedestrian-oriented space that meets the criteria of KZC 92.10.8 of this chapter and is in front of each facade.
  - 4) Provide at least one-half of the window area above the ground floor of each facade consistent with all of the following criteria (see Figure 92.30.D):
    - a) The windows must have glazed areas with dimensions less than five feet by seven feet.
    - b) The windows must be surrounded by trim, molding and/or sill at least two inches wide.
    - c) Individual window units must be separated from adjacent window units by at least six inches of siding or other exterior finish material of the building.
  - 5) Provide at least one-half of the window area above the ground floor of each facade facing a street or public park in panes with dimensions less than two feet by three feet and with individual panes separated by window mullions (see Figure 92.30.E).
  - 6) Provide a hipped or gable roof that covers at least one-half of the building footprint and has a slope equal to or greater than three feet vertical to 12 feet horizontal.
  - 7) If the main entrance of the building is on the facade of the building facing a street, through-block sidewalk, or public park, provide a covered porch or entry on the subject property at the building's main entrance. Pedestrian weather protection required under KZC 92.10.5 of this chapter may not be used to meet this requirement unless the required pedestrian weather protection covers an area at least 15 feet long by 15 feet wide and is available for outdoor display or outdoor vendors or contains pedestrian-oriented improvements or amenities beyond what is otherwise required.
  - 8) Provide one or more stories above the ground floor setback at least six feet from the ground floor facade facing the street, through block sidewalk, or a public park.
3. Techniques To Achieve Architectural Scale – The applicant shall use at least two of the following elements and features in the design and construction of all buildings that are three or more stories or have a building footprint of more than 10,000 square feet. As an alternative, the applicant may propose slight variations from the required dimensions noted in the following techniques, or other methods to comply with the requirements of this subsection. The City

### Individual Windows Option

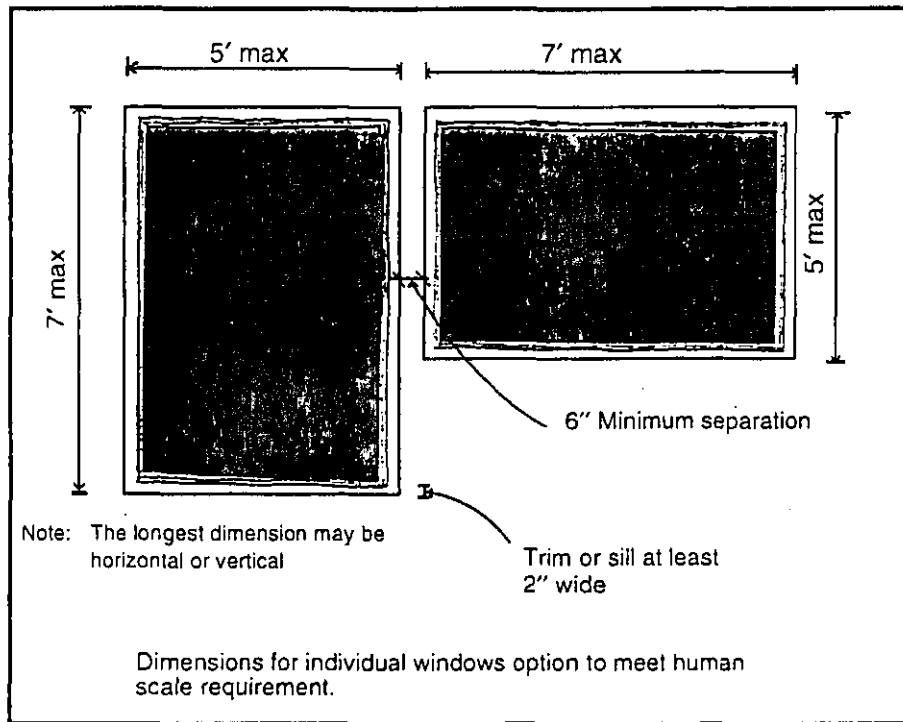

FIGURE ~~509.001.02~~ 92.30.D

### Multiple-Paned Fenestration Option

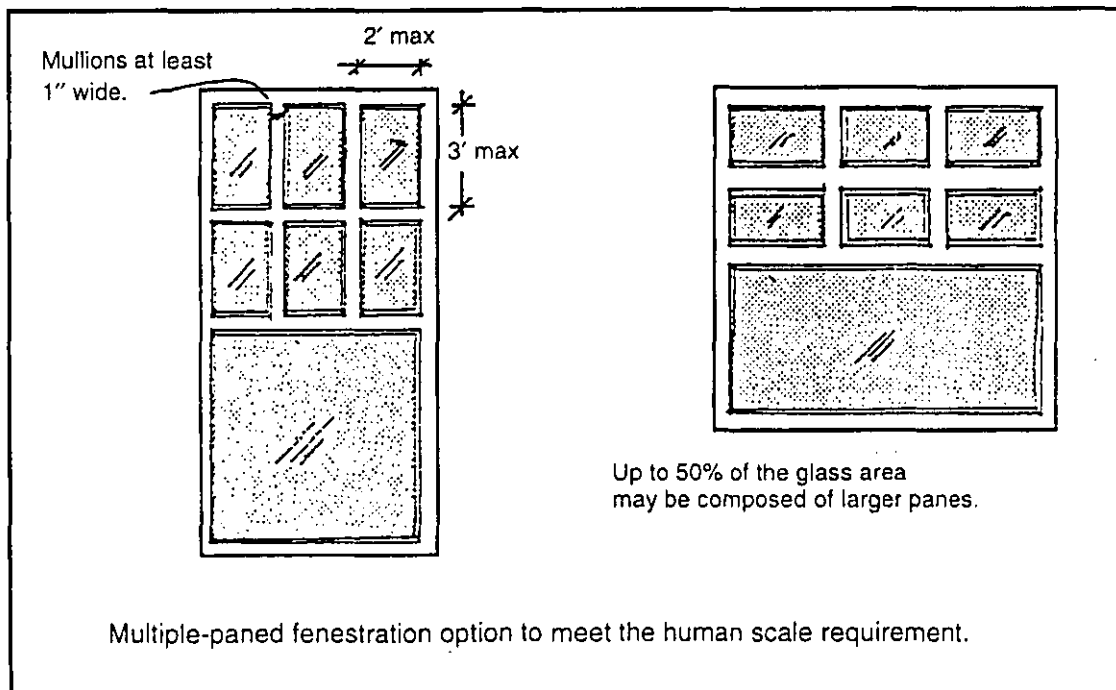

FIGURE ~~509.001.02~~ 92.30.E

may approve the proposal if it is consistent with the design guidelines and the Comprehensive Plan.

- a. All stories above the second story must be set back at least 10 feet from the ground floor facade along at least two facades of the building.
- b. On all building facades visible from a street or public park, provide horizontal modulation consistent with all of the following standards:
  - 1) The maximum allowable horizontal dimension of the facade between modulations is 70 feet;
  - 2) The minimum depth of each modulation, except balconies, is 10 feet; and
  - 3) The minimum width of each modulation, except balconies, is 15 feet.
- c. On all building facades visible from a street or public park, provide balconies consistent with the following standards:
  - 1) Balconies must be placed on at least every other floor above the ground floor;
  - 2) The maximum distance between balconies, measured horizontally, is 100 feet; and
  - 3) The minimum amount of floor area for each balcony is 100 square feet.
- d. Provide vertical modulation of the roofline of all facades of the building adjoining a street or public park. For buildings with flat, gabled, hipped or similar roofs, the maximum length of any continuous roof line, with a slope of less than three feet vertical to 12 feet horizontal, is 50 feet without being modulated. If modulation is necessary, at least one of the following methods must be used (see Figure 92.30.F):
  - 1) The height of the visible roofline must change at least eight feet if the adjacent roof segments are less than 50 feet in length.
  - 2) The height of the visible roofline must change at least 12 feet if the adjacent roof segments are greater than 50 feet in length.
  - 3) The length of a sloped or gabled roof line segment must be at least 20 feet. The minimum slope of the roof segment is three feet vertical to 12 feet horizontal.
- e. Buildings with other roof forms, such as arched, gabled, vaulted, dormered or sawtooth, must have a significant change in slope or significant change in roofline at least every 100 feet.

92.35

Building Material, Color and Detail

1. Required Elements – The applicant shall incorporate at least three of the following elements on each facade of a building that faces a street, through-block sidewalk or a public park. As an alternative, the applicant may propose other mechanisms for providing interesting visual detail to buildings, consistent with the design guidelines.



### Flat Roof Modulation Options

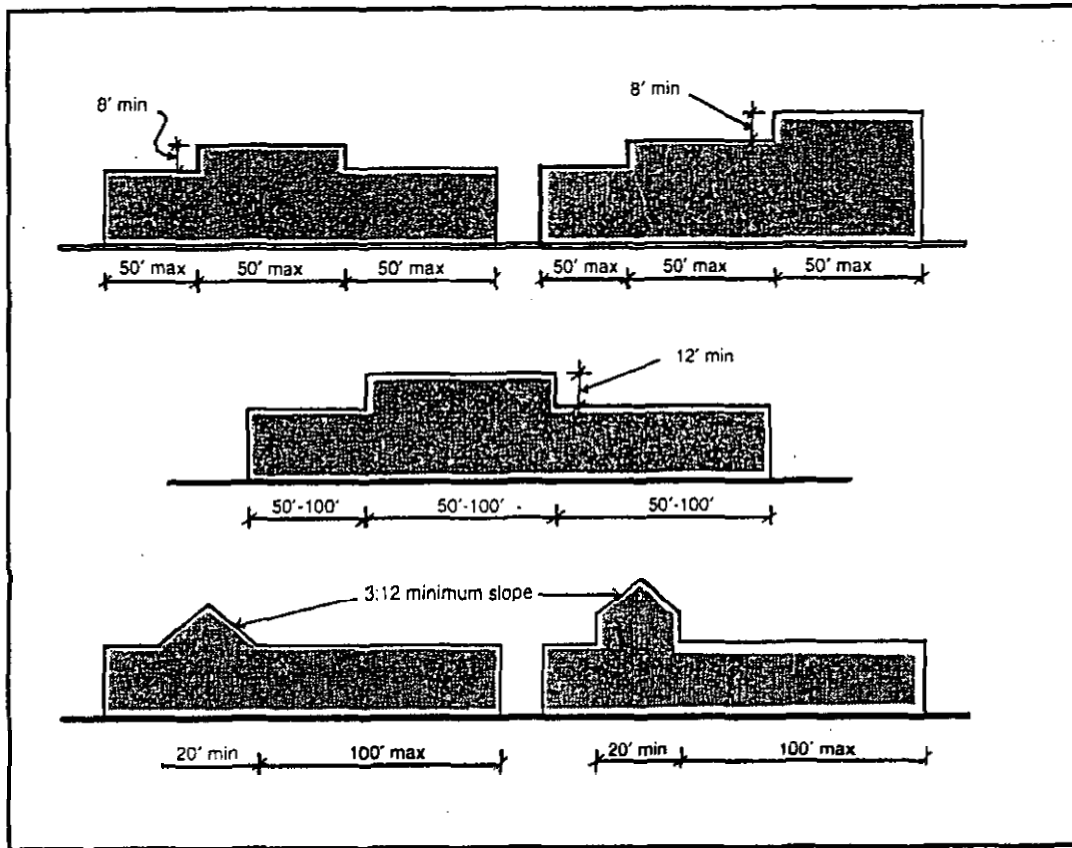

FIGURE 92.30.F

92.30.F

- a. Decorative roof lines, including ornamental molding, frieze or other roof line devices visible from the ground. Linear features must be at least eight inches wide, measured vertically.
- b. Decorative molding or framing details around all ground floor doors and windows. The molding or trim may have a traditional, contemporary, geometric or sculptural design.
- c. Decorative glazing on all ground floor doors and windows, including stained glass, crystal cut glass, etched glass or similar individualized and permanent treatment, but excluding single-colored glass, opaque glass or plastic. On all ground floor windows, this decorative glazing must have a surface area of at least 30 square feet.
- d. Railings, grill work, landscape guards or other similar elements including materials, design, configuration, embellishment or workmanship that exceeds the normal functional requirements for the element.
- e. Trellises or arbors having an area of at least 100 square feet and planted, consistent with the requirements of KZC 92.05.4 of this chapter, to achieve at least 30 percent coverage of the trellis or arbor with plant material within three years.
- f. Decorative light fixture or fixtures, either one if one-of-a-kind or custom-built or one every 30 feet along the facade of the building if not one-of-a-kind or custom-built, that meet either of the following criteria:
  - 1) Includes a diffuse, visible light source, such as a globe.
  - 2) Contains a shade or mounting that includes some use of material, configuration, shape, embellishment or detail that exceeds the normal functional requirement for the shade or mounting.
- g. Use of any of the following decorative materials:
  - 1) Any of the following decorative masonry elements:
    - a) Decorative masonry patterns, other than running bond pattern.
    - b) Bricks, tile, stone, cast stone or other masonry units of at least two colors installed in layers or tiers to form a geometric pattern.
    - c) Decorative bands of masonry, such as a soldier course of brick or multicolored ceramic tile band, in conjunction with another exterior surface material.
  - 2) Individualized wood patterns or continuous wood details, such as fancy butt shingles in a geometric pattern, decorative moldings, brackets, eave trim or lattice work.
  - 3) Ceramic tile, stone, glass blocks, camera glass or other similar materials incorporated into other compatible surface materials and used to form or create, or in conjunction with, a geometric pattern, distinctive shape, unusual surface treatment, special lighting or other decorative or textural element.
  - 4) Other materials with decorative or textural qualities, as demonstrated by architectural drawings and material samples, approved by the City as part of D.R.

- h. Decorative unit paving, including at least 50 square feet of multicolored tile, paver blocks, brick or other paving material in a decorative pattern, installed in a pedestrian-circulation area adjacent to the facade.
  - i. Artwork in the form of a mosaic mural, bas-relief sculpture, light sculpture, water sculpture, fountain, freestanding sculpture, art in pavement, murals, graphics or other forms, either freestanding in front of the facade or attached to the facade.
2. Prohibited Materials – The following materials may not be used on any exterior surface that is visible from any area beyond the subject property:
    - a. Mirrored glass.
    - b. Corrugated fiberglass.
    - c. Chain link fencing, except for temporary purposes, such as during construction.
  3. Metal Siding – Corner and edge trim must be used to cover exposed edges of metal siding. If metal siding covers more than 25 percent of a building's facade, the following regulations apply:
    - a. The siding must have a matted finish.
    - b. The siding must be in a neutral, earth tone or dulled color such as buff, grey, beige, tan, creme, white, barn-red, blue-grey, burgundy or ocher.
    - c. The facade must have visible window and door trim painted or finished in a color that is complementary to the siding color.
  4. Concrete Block – Any concrete block, masonry unit or cinder block wall that is visible from a street or public park must contain one or more of the following features or elements:
    - a. Use of textured blocks with surfaces such as split-faced or grooved.
    - b. Use of colored mortar complementary to the color of the blocks.
    - c. Use of other surface material such as bricks, glass blocks or tile as a significant feature of the wall.
  5. Awnings
    - a. The design of awnings should complement the architecture of the building. Steel and glass, fabric, and other materials of a more permanent nature are encouraged. Vinyl or plastic awnings and awnings used predominantly for advertising are discouraged.
    - b. Translucent awnings shall not be backlit. Lights directed downward mounted from internal awning frames are permitted. Lights mounted above awnings and directed downward are permitted.
  6. Covering of Existing Facades – Existing brick or cast stone masonry facades may not be covered with metal siding, metal screening, plastic siding, fiberglass siding, plywood siding, or wood siding materials. Other existing facades may be covered if consistent with the provisions of KZC 92.35.6. As part of D.R. for remodels, the City may require the removal of coverings.
  7. Building Cornerstone or Plaque – All commercial buildings designed for use by more than one tenant must have a building cornerstone or plaque, placed in a prominent location, consistent with the following standards:

- a. Building cornerstones must be constructed in carved stone, cast stone, carved masonry, terra cotta or other vandal-resistant material.
- b. Building plaques must be mounted no lower than two feet and no higher than 10 feet above ground and must be made of bronze, brass, anodized aluminum, porcelain enamel-covered steel or aluminum or other corrosion-resistant material.
- c. Building cornerstones and plaques must indicate the name of the building and, if known, the date of construction and architect.
- d. Building cornerstones and plaques may include the owner's name and other historical information.

**CBD**

- 8. Building Corners in the CBD – If the subject property is adjacent to the intersection of two streets, at least one of which is a pedestrian-oriented street, the applicant shall use one or more of the following elements or treatments in the design and construction of the corner of the building facing the intersection of the streets which includes the pedestrian-oriented street. As an alternative, the applicant may propose other techniques, elements or treatments in the design of the corner that are consistent with the design guidelines and the provisions of the Comprehensive Plan.
  - a. Provide at least 100 square feet of sidewalk area or pedestrian-oriented open space in addition to the area required to produce a 10-foot-wide sidewalk as required under KZC 92.10.1 of this chapter (see Figure 92.35.A).
  - b. Provide an entranceway to a store, building atrium or lobby, exterior courtyard or pedestrian-oriented open space (see Figure 92.35.B).
  - c. Provide a pedestrian pathway, at least eight feet in width that connects to another street, public feature or building (see Figure 92.35.B).
  - d. Provide one or more of the elements listed below on both sides of an axis running diagonally through the corner of the building and bisecting the angle formed by the two building facades (see Figure 92.35.C):
    - 1) A bay window or turret.
    - 2) A roof deck.
    - 3) Balconies above the ground floor.
    - 4) A building corner setback notch or curved facade surface.
    - 5) Sculpture or artwork, either bas-relief or figurative.
    - 6) Distinctive use of facade materials.
  - e. Provide special or unique treatment, other than the use of fabric or vinyl awnings, for pedestrian weather protection at the corner of the building.

### Options for Corner Setback Configurations

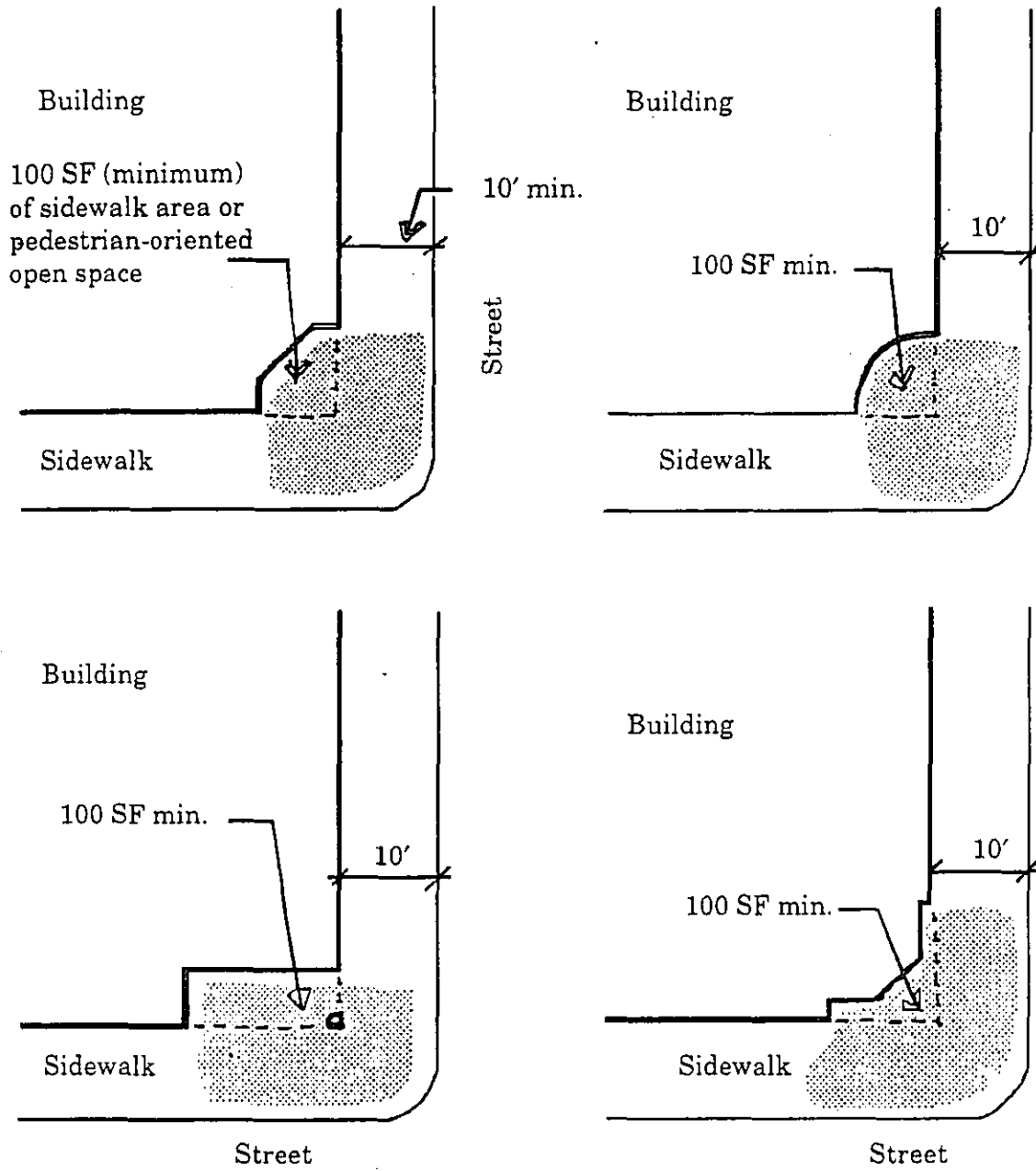
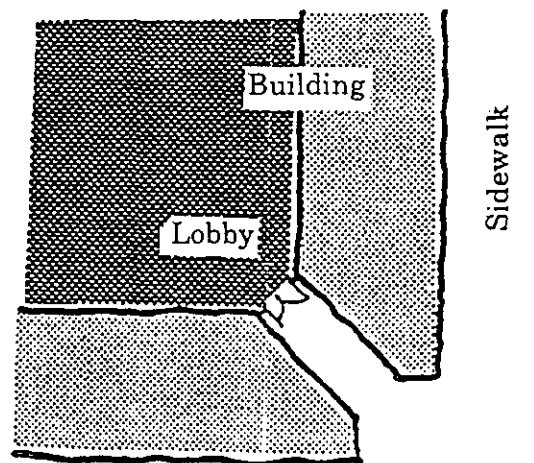
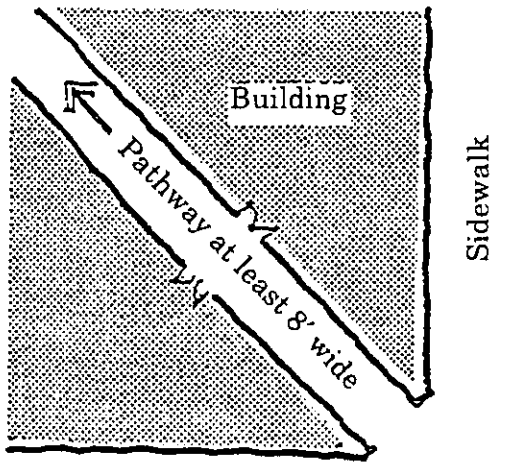
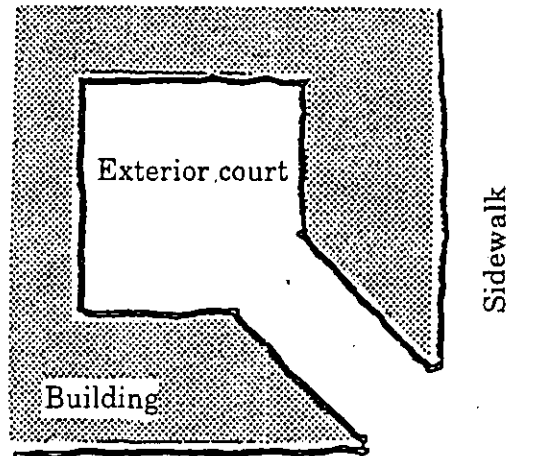
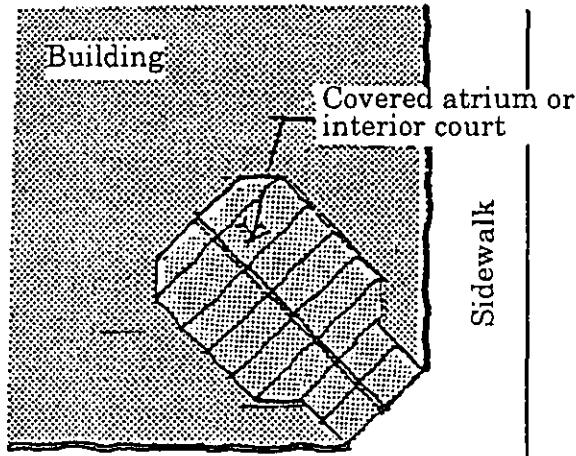

FIGURE ~~92.35.A~~

92.35.A

### Options for Corner Entry Elements



92.35.B

FIGURE 60-85-1-B

# Architectural Elements for Corners

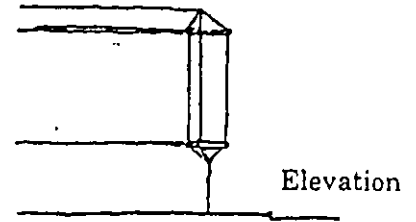

Elevation

Bay window

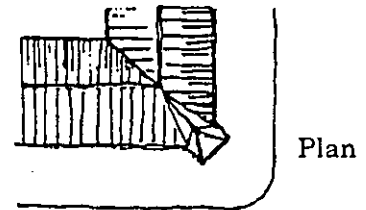

Plan

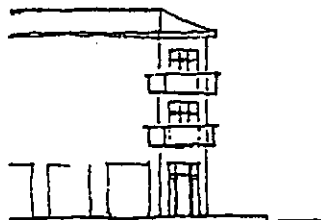

Balconies

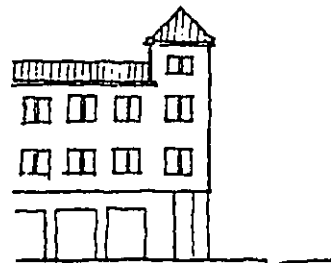
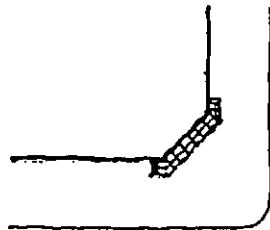

Turret

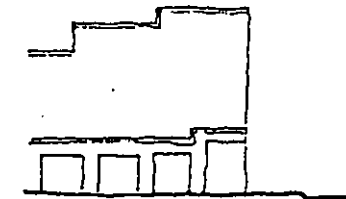
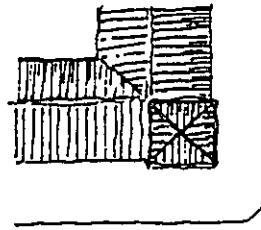

Corner accentuating roof line

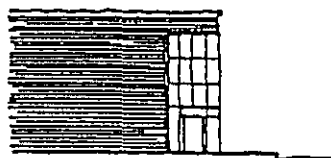
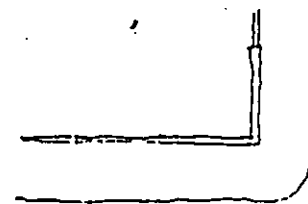

Distinctive use of materials

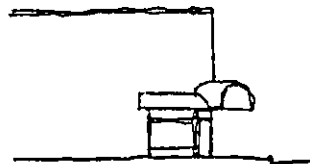
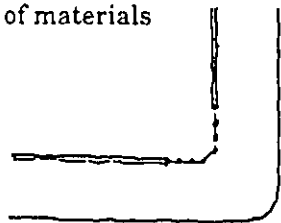

Canopy

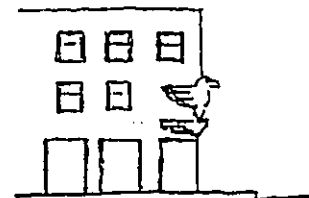
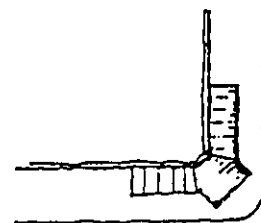

Sculpture

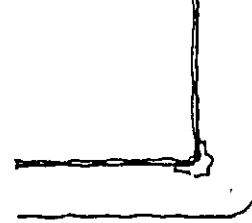

92.35.C

FIGURE ~~50-21-100~~

## TABLE OF CONTENTS

### Table of Revised Pages

Chapter 1	-	User Guide .....	1
Chapter 5	-	Definitions .....	5
Chapter 10	-	Legal Effect/Applicability .....	25
Chapter 15	-	Single-Family Residential (RS) Zones .....	29
Chapter 17	-	Single-Family Residential Annexation (RSX) Zones .....	37
Chapter 20	-	Multifamily Residential (RM) Zones .....	45
Chapter 25	-	Professional Office Residential (PR) Zones .....	53
Chapter 27	-	Professional Office (PO) Zones .....	61
Chapter 30	-	Waterfront District (WD) Zones	
		WDI Zone .....	67
		WDII Zone .....	81
		WDIII Zone .....	91
Chapter 35	-	Freeway Commercial (FC) Zones	
		FCI Zone .....	107
		FCII Zone .....	113
		FCIII Zone .....	123
Chapter 40	-	Neighborhood Business (BN) Zones .....	129
Chapter 45	-	Community Business (BC) Zones .....	135
Chapter 47	-	Community Business Annexation (BCX) Zones .....	143
Chapter 50	-	Central Business District (CBD) Zones	
		CBD-1 .....	151
		CBD-2 .....	155
		CBD-3 .....	169
		CBD-4 .....	175
		CBD-5 .....	179
		CBD-6 .....	183
		CBD-7 .....	191
		CBD-8 .....	197
Chapter 52	-	Juanita Business District (JBD) Zones	
		JBD-1 .....	237
		JBD-2 .....	247
		JBD-3 .....	255
		JBD-4 .....	261
		JBD-5 .....	269
		JBD-6 .....	285
Chapter 55	-	Light Industrial Technology (LIT) Zones .....	313
Chapter 57	-	Industrial Limited Commercial (ILC) Zones .....	321
Chapter 60	-	Planned Areas (PLA)	
		PLA1 .....	329
		PLA2 .....	337
		PLA3 .....	343
		PLA5 .....	363
		PLA6 .....	395
		PLA7 .....	463
		PLA8 .....	483
		PLA9 .....	491
		PLA10 .....	497



# Chapter 92 - Design Regulations

0-3833

PLA11 .....	515
PLA12 .....	521
PLA13 .....	523
PLA15 .....	541
PLA16 .....	565
PLA17 .....	571
Chapter 65 - Park/Public Use (P) Zone .....	589
Chapter 72 - Adult Activities Overlay Zone .....	591
Chapter 75 - Historic Landmark Overlay Zone .....	593
Chapter 80 - Equestrian Overlay Zone .....	597
Chapter 85 - Geologically Hazardous Areas .....	601
Chapter 90 - Drainage Basins .....	607
Chapter 95 - Landscaping .....	631
Chapter 100 - Signs .....	637
Chapter 105 - Parking And Parking Areas, Vehicle and Pedestrian Access, and Related Improvements .....	649
Chapter 110 - Required Public Improvements .....	661
Chapter 115 - Miscellaneous Use Development and Performance Standards .....	679
Chapter 117 - Personal Wireless Service Facilities .....	715
Chapter 120 - Variances .....	725
Chapter 125 - Planned Unit Development .....	727
Chapter 127 - Temporary Use .....	733
Chapter 130 - Rezone .....	735
Chapter 135 - Amendments to the Text of the Zoning Code .....	739
Chapter 140 - Amendments to the Comprehensive Plan .....	741
Chapter 142 - Design Review .....	743
Chapter 145 - Process I .....	753
Chapter 150 - Process IIA .....	763
Chapter 152 - Process IIB .....	777
Chapter 155 - Process III .....	789
Chapter 160 - Process IV .....	801
Chapter 161 - Process IVA .....	807
Chapter 162 - Nonconformance .....	811
Chapter 165 - Authority .....	821
Chapter 170 - Code Enforcement .....	825
Chapter 175 - Bonds .....	833
Chapter 180 - Plates .....	837

Ordinance Table

Interpretations

**CHAPTER 50 - CENTRAL BUSINESS DISTRICT (CBD) ZONES**

50.05 User Guide. The charts in KZC 50.12 contain the basic zoning regulations that apply in the CBD 1 zones of the City. Use these charts by reading down the left hand column entitled Use. Once you locate the use in which you are interested, read across to find the regulations that apply to that use.

**Section 50.10**

**Zone  
CBD-1**

**Section 50.10 – GENERAL REGULATIONS**

The following regulations apply to all uses in this zone unless otherwise noted:

1. Refer to Chapter 1 KZC to determine what other provisions of this Code may apply to the subject property.
2. Height measured at the midpoint of the frontage of the subject property on the abutting right-of-way, excluding First Avenue South. Buildings exceeding two stories must demonstrate compliance with the design regulations of KZC ~~50.65~~ <sup>Chapter 92</sup> and all provisions contained in the Downtown Plan. The City will determine compliance with these requirements through Design Review (D.R.).

50.14 User Guide. The charts in KZC 50.17 contain the basic zoning regulations that apply in the CBD 2 zones of the City. Use these charts by reading down the left hand column entitled Use. Once you locate the use in which you are interested, read across to find the regulations that apply to that use.

Section 50.15

Zone  
CBD-2

Section 50.15 – GENERAL REGULATIONS

The following regulations apply to all uses in this zone unless otherwise noted:

1. Refer to Chapter 1 KZC to determine what other provisions of this Code may apply to the subject property.
2. See KZC 50.20 for regulations regarding bulkheads and land surface modification.
3. Along Lake Street South, north of Kirkland Avenue, buildings exceeding one story above Lake Street South shall demonstrate compliance with the Design Regulations of KZC ~~50.65~~ <sup>Chapter 92</sup> and all provisions of the Downtown Plan. Through Design Review (D.R.) the City shall find that any allowance for additional height is clearly outweighed by identified public benefits such as through-block public pedestrian access or through-block view corridors (does not apply to Public Access Pier or Boardwalk and Moorage Facility for One or Two Boats uses).
4. In no case shall the height exceptions identified in KZC 50.62 and 115.60(2)(d) result in a structure which exceeds 28 feet above the abutting right-of-way (does not apply to Public Access Pier or Boardwalk, Moorage Facility for One or Two Boats uses and General Moorage Facility Uses).
5. South of Second Avenue South, maximum height of structure is three stories above Lake Street South as measured at the midpoint of the frontage of the subject property on Lake Street South. Buildings exceeding two stories shall demonstrate compliance with the design regulations of KZC ~~50.65~~ <sup>Chapter 92</sup> and all provisions of the Downtown Plan (does not apply to Public Access Pier or Boardwalk and Moorage Facility for One or Two Boats uses).
6. For purposes of measuring building height, if the subject property abuts more than one right-of-way, the applicant may choose which right-of-way shall be used to measure the allowed height of structure (does not apply to Public Access Pier or Boardwalk, Moorage Facility for One or Two Boats, and General Moorage Facility uses).
7. May not use land waterward of the high waterline to determine lot size or to calculate allowable density.
8. Development in this zone may also be regulated under the City's Shoreline Master Program; consult that document.

0-3833

50.34 User Guide. The charts in KZC 50.37 contain the basic zoning regulations that apply in the CBD 5 zones of the City. Use these charts by reading down the left hand column entitled Use. Once you locate the use in which you are interested, read across to find the regulations that apply to that use.

Section 50.35

Zone  
CBD-5

Section 50.35 – GENERAL REGULATIONS

The following regulations apply to all uses in this zone unless otherwise noted:

1. Refer to Chapter 1 KZC to determine what other provisions of this Code may apply to the subject property.
2. No portion of a structure above the elevation of Kirkland Way as measured at the midpoint of the frontage of the subject property on Kirkland Way may exceed the following:
  - a. Within 20 feet of Kirkland Way, 2 stories;
  - b. Within 40 feet of Kirkland Way, 4 stories;
  - c. Within 50 feet of Kirkland Way, 5 stories.
3. Buildings exceeding two stories above average building elevation shall demonstrate compliance with the design regulations of KZC ~~50.05~~ <sup>Chapter 92</sup> and the provisions of the Downtown Plan Chapter of the Comprehensive Plan. The City will use Design Review (D.R.) to determine compliance.
4. The minimum required yard abutting Peter Kirk Park is 10 feet. The required front yard is 0 feet for those portions of buildings with continuous retail or restaurant uses at street level. Kirkland Way shall be considered a *pedestrian-oriented street* if the front yard is less than 20 feet.
5. No portion of a structure within 100 feet of Peter Kirk Park shall exceed three stories above average building elevation.
6. Ground floor porches and similar entry features may encroach into the required front yard, provided the total horizontal dimensions of such elements may not exceed 25 percent of the length of the facade of the structure (does not apply to Public Park uses).
7. The entire zone must be physically integrated both in site and building design. Also, site design must include installation of pedestrian linkages consistent with the major pedestrian routes in the Downtown Plan chapter of the Comprehensive Plan, between public sidewalks and building entrances, and between walkways on the subject property and existing or planned walkways on abutting properties (does not apply to Public Utility, Government Facility or Community Facility and Public Park uses).

0-3833

DIRECTIONS: FIRST, read down to find use... THEN, across for REGULATIONS

Section 52.12	USE ↑ REGULATIONS ↑	Required Review Process	MINIMUMS			MAXIMUMS		Sign Category (See Ch. 100)	Required Parking Spaces (See Ch. 105)	Special Regulations (See also General Regulations)
			Lot Size	REQUIRED YARDS (See Ch. 115)		Height of Structure	Landscape Category (See Ch. 95)			
			Front	Side	Rear	Lot Coverage				
.010	Vehicle Service Station. See Special Regulation 1.	D.R., Chapter 142 KZC.	0'	0'	0'	80%	A	See KZC 105.25.	<ol style="list-style-type: none"> <li>May not be more than two vehicle service stations at any intersection.</li> <li>Gas pump islands must be setback at least 20 feet from all property lines. Canopies and covers over gas pump islands may not be closer than 10 feet to any property line. See KZC 115.105, Outdoor Use, Activity and Storage, for further regulations.</li> </ol>	
.020	Automotive Service Center See Special Regulation 1.		0'	0'	0'			<ol style="list-style-type: none"> <li>1 per each 250 sq. ft. of gross floor area. See Spec. Reg. 3.</li> </ol>	<ol style="list-style-type: none"> <li>This use specifically excludes new or used vehicle sales or rentals.</li> <li>No openings (i.e., doors, windows which open, etc.) shall be permitted in any facade of the building adjoining a residential use. Windows are permitted if they are triple-paned and unable to be opened.</li> <li>Ten (10) percent of the required parking spaces on site must have a minimum dimension of 10 feet wide by 30 feet long for motor home/travel trailer use.</li> <li>Storage of used parts and tires must be conducted entirely within an enclosed structure. See also the section in Chapter 115 entitled "Outdoor Use, Activity and Storage" for additional regulations.</li> <li>Prior to occupancy of the structure, documentation must be provided and stamped by a licensed professional verifying that the expected noise to be emanating from the site adjoining to any residential use complies with the standards set forth in WAC 173-60-040(1) for a Class B source property and a Class A receiving property.</li> </ol>	
.030	Retail Establishment providing Boat Sales, Service, or Repair. See Special Regulation 1.							See KZC 105.25.	<ol style="list-style-type: none"> <li>Boat rental and used boat sales are allowed as part of this use.</li> <li>Storage of parts must be conducted entirely within an enclosed structure.</li> <li>Outdoor boat parking and storage areas must be buffered as required for a parking area per design regulations. KZC <del>52.56-4(d) and (e)</del>. See also KZC 115.105, Outdoor Activity and Storage, for further regulations.</li> </ol>	
.040	Restaurant or Tavern						D	1 per each 100 sq. ft. of gross floor area.	92.25, 4 and 5	

Section 52.12

Zone JBD-1

USE ZONE CHART

**DIRECTIONS: FIRST, read down to find use... THEN, across for REGULATIONS**

Section 52.12	USE REGULATIONS	MINIMUMS			MAXIMUMS		Landscape Category (See Ch. 95)	Sign Category (See Ch. 100)	Required Parking Spaces (See Ch. 105)	Special Regulations (See also General Regulations)	
		Required Review Process	Lot Size	REQUIRED YARDS (See Ch. 115)		Lot Coverage					Height of Structure
				Front	Side						
.120	Development containing two or more of the following uses: - Retail Establishments, including Restaurants, Taverns, and Fast Food Restaurants - Office Uses - Stacked or Attached Dwelling Units (continued)								6. Any development approved under this provision must include a comprehensive design plan for all signs on the subject property. 7. If the development contains restaurant, tavern, fast food restaurant, or retail use, then sign category E applies. Otherwise, sign category D applies. 8. Drive-in and drive-through facilities are permitted only if these facilities do not compromise the pedestrian orientation of the development. The location and specific design of the facilities requires Planning Official approval. 9. Restaurants, taverns, fast food restaurants, and retail establishments selling goods and services should be the predominate use on the ground floor of structures. Other permitted uses, including dwelling units, may be allowed on the ground floor of structure if this does not compromise the desired mixed use character of the development. 10. The subject property must contain landscaped public open space in conjunction with a pedestrian path or series of pedestrian paths that link the East Ridge to the subject property and the subject property to Juanita Beach Park. 11. The subject property must have access points from at least two public rights-of-way. 12. Buildings exceeding 35 feet above average building elevation shall be permitted only if design techniques are used to minimize perceived building mass and achieve superior architectural and human scale from abutting rights-of-way and public open spaces. In meeting this requirement, buildings shall exceed the design requirements of KZC 52.50-54 and 55 and will normally include terracing of upper floors and modulation of front facades. 13. The applicant shall comply with the Special and General Regulations established in this Chapter for the uses that are proposed to be included on the subject property unless the City determines that they conflict with regulations applicable to this use listing. 14. The City may approve the proposed development only if it contains public amenities such as plazas, sculptures, fountains, water fountains, and pocket parks. 15. Buildings exceeding 30 feet above average building elevation shall demonstrate compliance with the design regulations of KZC 52.50-55 and the provisions of the Juanita Business District Chapter of the Comprehensive Plan. The City will use Process IIA, Chapter 152 KZC, to determine compliance.		

92.30.2 and 3

Chapter 92

USE ZONE CHART

DIRECTIONS: FIRST, read down to find use... THEN, across for REGULATIONS												
Section 52.17	USE ↓ REGULATIONS ↑	Required Review Process	MINIMUMS			MAXIMUMS		Landscape Category (See Ch. 95)	Sign Category (See Ch. 100)	Required Parking Spaces (See Ch. 105)	Special Regulations (See also General Regulations)	
			Lot Size	REQUIRED YARDS (See Ch. 115)			Lot Coverage					Height of Structure
				Front	Side	Rear						
.010	Vehicle Service Station See Special Regulation 1.	D.R., Chapter 142 KZC.	22,500 sq. ft.	0'	0'	0'	80%	26' above average building elevation.	A	E	See KZC 105.25.	<ol style="list-style-type: none"> <li>1. May not be more than two vehicle service stations at any intersection.</li> <li>2. Gas pump islands must be setback at least 20 feet from all property lines. Canopies and covers over gas pump islands may not be closer than 10 feet to any property line. See KZC 115.105, Outdoor Use, Activity and Storage, for further regulations.</li> </ol>
.020	Automotive Service Center See Special Regulation 1.		None	0'	0'	0'					1 per each 250 sq. ft. of gross floor area. See Spec. Reg. 3.	<ol style="list-style-type: none"> <li>1. This use specifically excludes new or used automobile sales or rentals.</li> <li>2. No openings (i.e., doors, windows which open, etc.) shall be permitted in any facade of the building adjoining a residential use. Windows are permitted if they are triple-paned and unable to be opened.</li> <li>3. Ten percent of the required parking spaces on site must have a minimum dimension of 10-feet wide by 30-feet long for motor home/travel trailer use.</li> <li>4. Storage of used parts and tires must be conducted entirely within an enclosed structure. See also the section in Chapter 115 entitled "Outdoor Use, Activity and Storage" for additional regulations.</li> <li>5. Prior to occupancy of the structure, documentation must be provided and stamped by a licensed professional verifying that the expected noise to be emanating from the site adjoining to any residential use complies with the standards set forth in WAC 173-60-040(1) for a Class B source property and a Class A receiving property.</li> </ol>
.030	Retail Establishment providing Boat Sales, Service, or Repair See Special Regulation 1.										See KZC 105.25.	<ol style="list-style-type: none"> <li>1. Boat rental and used boat sales are allowed as part of this use.</li> <li>2. Storage of parts must be conducted entirely within an enclosed structure.</li> <li>3. Outdoor boat parking and storage areas must be buffered as required for a parking area per design regulations, KZC 52.60-4(d) and (e). See also KZC 115.105, Outdoor Activity and Storage for further regulations.</li> </ol>
.040	Restaurant or Tavern								D		1 per each 100 sq. ft. of gross floor area.	
.050	Fast Food Restaurant								D See Spec. Reg. 2.		1 per each 80 sq. ft. of gross floor area	<ol style="list-style-type: none"> <li>1. Must provide one outdoor waste receptacle for every eight parking stalls.</li> <li>2. Landscape Category B will be required if the use includes drive-through facilities.</li> </ol>
.060	A retail establishment providing entertainment, recreational, or cultural activities								D		See Section 105.25.	

**DIRECTIONS: FIRST, read down to find use... THEN, across for REGULATIONS**

Section 52.27 USE REGULATIONS	Required Review Process	MINIMUMS			MAXIMUMS		Landscape Category (See Ch. 95)	Sign Category (See Ch. 100)	Required Parking Spaces (See Ch. 105)	Special Regulations (See also General Regulations)
		Lot Size	REQUIRED YARDS (See Ch. 115)		Lot Coverage	Height of Structure				
		Front	Side	Rear						
.010 Retail Establishment providing Boat Sales, Service, or Repair. See Special Regulation 1.	D.R., Chapter 142 KZC.	0'	0'	0'	80%	26' above average building elevation.	A	E	See KZC 105.25.	1. Boat rental and used boat sales are allowed as part of this use. 2. Storage of parts must be conducted entirely within an enclosed structure. 3. Outdoor boat parking and storage areas must be buffered as required for a parking area per design regulations, KZC 52.50-4(d) and (e). See also KZC 115.105, Outdoor Activity and Storage for further regulations. <i>92.25.4 and 5</i>
.020 Restaurant or Tavern							C		1 per each 100 sq. ft. of gross floor area.	
.030 Fast Food Restaurant									1 per each 80 sq. ft. of gross floor area.	1. Must provide one outdoor waste receptacle for every eight parking stalls. 2. Drive-through facilities are prohibited.
.040 A retail establishment providing entertainment, recreational, or cultural activities									See KZC 105.25.	



DIRECTIONS: FIRST, read down to find use... THEN, across for REGULATIONS												
Section 52.32	USE ↓ REGULATIONS ↑	Required Review Process	MINIMUMS			MAXIMUMS		Landscape Category (See Ch. 95)	Sign Category (See Ch. 100)	Required Parking Spaces (See Ch. 105)	Special Regulations (See also General Regulations)	
			Lot Size	REQUIRED YARDS (See Ch. 115)			Lot Coverage					Height of Structure
				Front	Side	Rear						
.010	Retail Establishment providing Boat Sales, Service, or Repair. See Special Regulation 1.	D.R., Chapter 142 KZC.	None	0'	0'	0'	80%	26' above average building elevation.	A	E	See KZC 105.25.	1. Boat rental and used boat sales are allowed as part of this use. 2. Gross floor area for this use may not exceed 10,000 square feet. 3. Storage of parts must be conducted entirely within an enclosed structure. 4. Outdoor boat parking and storage areas must be buffered as required for a parking area per design regulations, KZC 52.50.4(d) and (e). See also KZC 115.105, Outdoor Activity and Storage, for further regulations.
.020	Restaurant or Tavern								C		1 per each 100 sq. ft. of gross floor area.	1. Gross floor area for this use may not exceed 10,000 square feet.
.030	Fast Food Restaurant								1 per each 80 sq. ft. of gross floor area.		1. Must provide one outdoor waste receptacle for every eight parking stalls. 2. Drive-through facilities are prohibited. 3. Gross floor area for this use may not exceed 10,000 square feet.	
.040	A retail establishment providing entertainment, recreational, or cultural activities								See KZC 105.25.		1. Gross floor area for this use may not exceed 10,000 square feet.	

92.25.4 and 5

- 2) Vegetation that will provide comparable screening to a five-foot fence within two years of planting; and
- 3) Along the entire easement or tract outside the required front yard.

h. See KZC 105.20 for providing adequate guest parking spaces.

105.12 Maximum Allowable Grade

The slope of vehicular access easements and tracts, and the slope of entrance and exit driveways, except driveways for detached single-family residences, shall not exceed six percent for the first 20 feet from the face of the abutting right-of-way curb. Thereafter, the slope shall not exceed 15 percent. The Departments of Public Works and Fire are authorized to modify the standards for maximum allowable grade on a case-by-case basis.

105.15 Exception in the CBD

If the subject property is within the Central Business District Zone, the requirements contained within Chapter 50 KZC supersede any conflicting provisions of this chapter. The provisions of this chapter that do not conflict with Chapter 50 KZC apply to properties in the CBD.

105.17 Site Plan Review

Before commencing any development activity on a new parking area or any alteration or improvement to an existing parking area (except routine maintenance), the applicant must submit a site plan for approval by the Planning Department. Parking areas must comply with the Zoning Code. The site plan must be drawn to scale and show the following items:

1. All buildings on the subject property.
2. All parking and driving areas and pedestrian and bicycle facilities on the subject property.
3. All landscaping and buffering on the subject property.
4. The nature of the use of all adjoining properties.
5. All adjoining rights-of-way.
6. All transit stops and/or facilities on abutting rights-of-way.

105.18 Pedestrian, Bicycle, and Transit Facilities

1. The applicant shall comply with the requirements for each use specified in the following chart:

## Chapter 142 – DESIGN REVIEW

## Sections:

- 142.05 User Guide
- 142.15 Development Activities Requiring D.R. Approval
- 142.17 Design Review Process
- 142.20 Timing
- 142.25 Administrative Design Review (A.D.R.)
- 142.35 Design Board Review (D.B.R.)
- 142.40 Appeals of Design Review Board Decisions
- 142.50 Modifications
- 142.55 Lapse of Approval
- 142.60 Bonds

142.05 User Guide

Various places in this code indicate that certain developments, activities, or uses are required to be reviewed through design review or D.R. Design review may either be administrative design review (A.D.R.) or design board review (D.B.R.). This chapter describes these design review processes.

142.15 Development Activities Requiring D.R. Approval

92.35, 2 and 5

1. All development activities subject to KZC ~~50-65(6)(b), (c), and (f)~~ and KZC ~~52-50(6)(b), (c), and (f)~~ need not be reviewed through D.R., but shall comply with this chapter.
2. The following development activities are subject to D.R. unless subsection (3) of this section applies:
  - a. The development of an undeveloped site.
  - b. The addition of new floor area to an existing building.
  - c. A change to the exterior appearance of over 25 percent of a facade visible from a street or park.
3. The following activities are not subject to D.R.:
  - a. Any activity which does not require a building permit; or
  - b. Any activity on the exterior of a building of which the total cost or fair market value, whichever is higher, does not exceed \$10,000; or
  - c. Interior work which does not alter the exterior of the structure; or
  - d. Normal building maintenance including the repair or maintenance of structural members.
4. See also KZC 162.35, Certain Nonconformances Specifically Regulated, for additional information regarding the application of design regulations to existing development and remodels. The City encourages voluntary compliance with the design regulations, the Comprehensive Plan, and design guidelines even for projects which do not require D.R. approval according to the terms of this subsection.

- 1) The request results in superior design and fulfills the policy basis for the applicable design regulations and design guidelines;
- 2) The departure will not have any substantial detrimental effect on nearby properties and the City or the neighborhood.

142.35 Design Board Review (D.B.R.)

1. Public Meetings – All meetings of the Design Review Board shall be public meetings and open to the public.
2. Authority – The Design Review Board shall review projects for consistency with the following:
  - a. Design guidelines for pedestrian-oriented business districts, as adopted in Chapter 3.30 KMC.
  - b. The design regulations contained in ~~KZC 50.63 and 52.50~~ <sup>chapter 92</sup>. To the extent that the standards of the design guidelines or design regulations address the same issue but are not entirely consistent or contain different levels of specificity, the Design Review Board shall determine which standard results in superior design.
  - c. The downtown plan and Juanita Business District Plan contained in the Comprehensive Plan.

The Design Review Board is authorized to approve minor variations in minimum required yards; provided, that the variation complies with the criteria of KZC 142.25(5)(d).

3. Pre-Design Conference – Before applying for D.B.R. approval, the applicant shall attend a pre-design conference with the Planning Official. The conference will be scheduled by the Planning Official upon written request by the applicant. The purpose of this conference is for the Planning Official to discuss how the design regulations, design guidelines, and other applicable provisions of this code and the Comprehensive Plan relate to the proposed development and to assist the applicant in preparing for the conceptual design conference.
4. Conceptual Design Conference – Before applying for design review approval, the applicant shall attend a conceptual design conference with the Design Review Board. The conference will be scheduled by the Planning Official to occur within 30 days of written request by the applicant. The purpose of this conference is to provide an opportunity for the applicant to discuss the project concept with the Design Review Board and:
  - a. To discuss how the design regulations, design guidelines and other applicable provisions of the Comprehensive Plan affect or pertain to the proposed development;
  - b. For the Design Review Board to designate which design regulation, design guidelines and other applicable provisions of the Comprehensive Plan apply to the proposed development based primarily on the location and nature of the proposed development; and
  - c. For the Design Review Board to determine what models, drawings, perspectives, 3-D CAD model, or other application materials the applicant will need to submit with the design review application.
5. Application – Following the conceptual design conference, the applicant shall submit the design review application on a form provided by the Planning Department. The application shall include all documents and exhibits listed on the application, as well as all application materials required as a result of the conceptual design conference.

burse the City for the cost of removing the sign(s) if, after the specified time, the prescribed minor nonconforming element(s) is not brought into conformance.

- 3) For purposes of this section, "repair" shall mean the work that is necessary to restore a sign to its former appearance subsequent to a sudden, accidental event.

6. Nonconforming Landscaping, Buffers and Paving

- a. The landscaping requirements of KZC 95.20, 105.75, and 105.80 must be brought into conformance as much as is feasible, based on available land area, in either of the following situations:

- 1) An increase in gross floor area of any structure; or
- 2) An alteration to any structure, the cost of which exceeds 50 percent of the replacement cost of the structure.

- b. Landscape buffers must be brought into conformance in either of the following situations:

- 1) An increase in gross floor area of any structure (the requirement to provide conforming buffers applies only to the new gross floor area); or
- 2) A change in use on the subject property and the new use requires larger buffers than the former use.

- c. Parking lot surfaces must be brought into conformance in any of the following situations:

- 1) An increase in gross floor area of any use; or
- 2) A change in use on the subject property and the new use requires more parking than the former use; or
- 3) An alteration to any structure, the cost of which exceeds 50 percent of the replacement cost of the structure.

7. Nonconforming Height, Setbacks and View Corridors

Any structural alteration of a roof or exterior wall which does not comply with height, setback or view corridor standards will require that the nonconforming height, setback or view corridor be brought into conformance. Excepted from this section is the repair or maintenance of structural members.

8. CBD and JBD Design Regulations

- a. The provisions of this subsection (8) regulate under what circumstances nonconformance with the CBD and JBD design regulations of KZC ~~50.05 and 52.50~~ must be corrected. Compliance with CBD and JBD design regulations is only required when D.R. is required pursuant to Chapter 142 KZC. However, the City encourages voluntary compliance with the design regulations even for projects which do not require D.R. approval.

- b. If the applicant proposes to modify a building or site (or portions thereof) that does not conform to the design regulations, then the nonconforming elements on or within the building or site (or portions thereof) must be brought into conformance to the greatest extent feasible, as determined by the City, depending on the scope of the project.

*Chapter 92*

PUBLICATION SUMMARY  
ORDINANCE NO. 3833

AN ORDINANCE OF THE CITY OF KIRKLAND RELATING TO ZONING, PLANNING, AND LAND USE AND AMENDING PORTIONS OF ORDINANCE 3719 AS AMENDED, THE KIRKLAND ZONING ORDINANCE (FILE NO. IVA-01-72); ADOPTING MINOR AMENDMENTS TO PROMOTE CLARITY, ELIMINATE REDUNDANCY, AND CORRECT INCONSISTENCIES PURSUANT TO CHAPTER 161 KZC.

SECTION 1. Identifies specific amendments to Ordinance 3719, as amended, the Kirkland Zoning Code. Deletes Section 50.65, Design Regulations for the Central Business District and Section 52.50, Design Regulations for the Juanita Business District and replaces them with Chapter 92, Design Regulations. Amends other sections of the KZC to reference the newly created Chapter rather than the deleted sections.

SECTION 2. Provides a severability clause for the ordinance.

SECTION 3. Authorizes publication of the ordinance by summary, which summary is approved by the City Council pursuant to Section 1.08.017 Kirkland Municipal Code and establishes the effective date as five days after publication of summary.

SECTION 4. Establishes certification by City Clerk and notification of King County Department of Assessments.

The full text of this Ordinance will be mailed without charge to any person upon request made to the City Clerk for the City of Kirkland. The Ordinance was passed by the Kirkland City Council at its regular meeting on the 19th day of March, 2002.

I certify that the foregoing is a summary of Ordinance 3833 approved by the Kirkland City Council for summary publication.

  
City Clerk